

W & A

PTO POWER DITCHER

OPERATOR'S MANUAL

INCLUDING PARTS

TO THE OWNER:

Congratulations on your purchase of a new W & A PTO Ditcher. Your selection is an indication of your awareness of the need for intensive engineering, research, design, durability and dependability that has gone into its production.

Be sure to read all the instructions in this manual before placing the machine in use. Safety precautions along with adjustments should be learned and also taught to anyone who operates the machine. Remember, an implement which is properly maintained, adjusted, and safely operated saves time, labor and money.

After the operating season, thoroughly clean your ditcher and inspect it. Preventive maintenance pays dividends. Your dealer has original equipment parts which assure proper fit and best performance.

Thank you for purchasing this W&A product.

For your convenience, please fill in the following:

Model: _____ Serial No. _____

Dealer Name: _____ Date Purchased _____



Quality Products from

W & A MANUFACTURING COMPANY

P.O. Box 5238, Pine Bluff, Arkansas 71611

Phone: (870) 534-7420

Fax: (800) 336-1318

Website: www.wamfgco.com

SAFETY

SI NO LEE INGLES, PIDA AYUDA A AIGUIEN QUE SI LO LEA PARA QUE LE TRADUZCA LAS MEDIDAS DE SEGURIDAD.



THIS SYMBOL MEANS

-ATTENTION!

-BECOME ALERT!

-YOUR SAFETY IS INVOLVED!

SIGNAL WORDS:

The signal words DANGER, WARNING and CAUTION are used with the safety messages in this manual and with each safety sign. They are defined as follows:

DANGER: Indicates an imminently hazardous situation that, if not avoided, will result in death or serious injury. This signal word is to be limited to the most extreme situations typically for machine components which, for functional purposes, cannot be guarded. The color for DANGER is RED.

WARNING: Indicates a potentially hazardous situation that, if not avoided, could result in death or serious injury, and includes hazards that are exposed when guards are removed. It may also be used to alert against unsafe practices. The color for WARNING is ORANGE.

CAUTION: Indicates a potentially hazardous situation that, if not avoided, may result in minor or moderate injury. It may also be used to alert against unsafe practices. The color for CAUTION is YELLOW.

- Safety of the operator and bystanders is one of the main concerns in designing and developing our products. However, every year accidents occur which could have been avoided by a few seconds of thought and a more careful approach to handling equipment. You, the operator, can avoid many accidents by observing the following precautions in this manual. To avoid personal injury or death, study the following precautions and insist those working with you, or for you, follow them.



If you have any questions not answered in this manual, require additional copies or the manual is damaged, please contact your dealer or W & A Manufacturing Company, P. O. Box 5238, Pine Bluff, Arkansas 71611. (Telephone) 870-534-7420, (FAX) 870-534-1318
Manuals can also be found at www.wamfgco.com



This is the safety alert symbol. When you see this symbol on your machine or in this manual, be alert to the potential for personal injury or death. Follow the recommended precautions!

SI NO LEE INGLES, PIDA AYUDA A AIGUIEN QUE SI LO LEA PARA QUE LE TRADUZCA LAS MEDIDAS DE SEGURIDAD.



GENERAL SAFETY REQUIREMENTS



- Safety of the operator and bystanders is one of the main concerns in designing and developing a ditcher. However, every year accidents occur which could have been avoided by a few seconds of thought and a more careful approach to handling equipment. You, the operator, can avoid many accidents by observing the following precautions in this manual. To avoid personal injury or death, study the following precautions and insist those working with your, or for you, follow them.
- Before operating your PTO Ditcher, thoroughly read and understand your operator's manual. If you do not understand any portion of the operator's manual, contact your dealer or W & A Manufacturing Company immediately.
- This equipment is dangerous to children and persons unfamiliar with its operation. The operator should be a responsible adult familiar with farm machinery and trained in this equipment's operations. **Do not allow persons to operate or assemble this unit until they have read this manual and have developed a thorough understanding of the safety precautions and of how it works.**
- Under no circumstances should children be allowed to operate this equipment.
- Never use alcoholic beverages or drugs which can hinder alertness or coordination while operating this equipment. Consult your doctor about operating this machine while taking prescription medications.
- Clear the area of people, especially children, before starting unit.
- Do not allow anyone to ride on any part of the equipment for any reason.
- Place all controls in neutral, stop tractor engine, set park brake, and wait for all moving parts to stop before service, adjusting, repairing or unplugging.
- If safety signs are missing, unreadable, or damaged, they must be replaced. See list of safety signs. Keep safety signs clean and legible. Do not paint over safety signs.

- If the elderly are assisting with farm work, their physical limitations need to be recognized and accommodated.
- Furnish this manual to the new owner if the machine is sold.
- Use a tractor equipped with a Roll Over Protective System (ROPS).
- Inspect machine daily for worn parts, leaks, and make necessary repairs. Tighten all bolts and make sure all fasteners are in place.
- Never exceed the limits of a piece of machinery.. If its ability to do a job, or to do so safely, is in question - **DON'T TRY IT.**
- Unauthorized modifications to the machine may impair the function and/or safety and affect machine life. Make NO unauthorized modifications.
- Never stand between implement and tractor when hitching. Extreme care should be used to prevent injury to the hands or fingers. *Stop tractor engine and set brake before installing hitch pins.*
- Lower machine before servicing, adjusting, leaving, or storing ditcher.
- Raised equipment can fall unexpectedly and crush persons underneath. Never allow anyone to enter the area underneath raised equipment during operation.
- Do not read, eat, drink, talk or text or use a mobile phone while using this equipment.
- Review the safety instructions with all users annually.



SAFETY TRAINING



- Safety is a primary concern in the design and manufacture of our products. Unfortunately, our efforts to provide safe equipment can be wiped out by a single careless act of an operator or bystander.
- In addition to the design and configuration of equipment, hazard control and accident prevention are dependent upon the awareness, concern, prudence, and proper training of personnel involved in the operation, transport, maintenance and storage of this ditcher.
- It has been said, “The best safety device is an informed, careful operator.” We ask you to be that kind of an operator. Its the operator’s responsibility to read and understand ALL Safety and Operating instructions in the manual and to follow these. Accidents can be avoided.

- Working with unfamiliar equipment can lead to careless injuries. Read this manual, and the manual of your tractor, before assembly or operating, to acquaint yourself with the machines. If this machine is used by any person other than yourself, or is loaned or rented, it is the ditcher owner's responsibility to make certain that the operator, prior to operating:
 1. Reads and understands the operator's manual.
 2. Is instructed in safe and proper use.
- Know your controls and how to stop tractor, engine, and ditcher quickly in an emergency. Read this manual and the one provided with your tractor.
- Train all new personnel and review instructions frequently with existing workers. Be certain only properly trained and physically able person will operate the ditcher. A person who has not read and understood all operating and safety instructions is not qualified to operate the machine. An untrained operator exposes himself and bystanders to possible serious injury or death. If the elderly are assisting with farm work, their physical limitations need to be recognized and accommodated.



TRANSPORTING



- Comply with all federal, state, and local laws for implement transport on public roads.
- At all times, when driving the tractor and equipment on the road or highway under 20 mph (32 kph) use flashing amber warning lights and a slow moving vehicle (SMA) identification emblem and appropriate lighting to meet local regulations. Avoid transporting at night or low light conditions. Do not exceed 20 mph (32 kph). Reduce speed on rough roads and surfaces.
- Plan your route to avoid heavy traffic.
- Do not drink and drive.
- Turn curves or go up and down hills at a low speed and at a gradual steering angle. Make certain that at least 20% of the tractors weight is on the front wheels to maintain safe steering. Slow down on rough or uneven surfaces.
- Never allow riders on either tractor or ditcher.
- Make sure that the brake pedal latch is engaged. You must lock brake pedals together for road travel.
- Slow down and signal before turning.



OPERATIONS



- The use of this equipment is subject to certain hazards which cannot be protected against by mechanical means or product design. All operators must read and understand this entire manual, paying particular attention to safety and operating instructions prior to using. If there is something in this manual you do not understand, ask your supervisor, your dealer, or phone W&A Manufacturing Company (870-534-7420) to have it explained to you.
- Most accidents occur because of neglect or carelessness. Keep all helpers and bystanders at least several hundred feet from an operating ditcher. Only properly trained people should operate this machine.
- Clear area to be ditched of stones, branches or other debris that might be thrown, causing injury or damage.
- Operate only in daylight.
- Ensure ditcher is properly mounted, adjusted and in good operating condition.
- Ensure that all safety shielding and safety signs are properly installed and in good condition.
- The majority of accidents involve entanglement on the driveline, injury of bystanders by thrown objects thrown by the rotating blades, and operators being knocked off the tractor by low hanging limbs and then being run over by the ditcher. Accidents are most likely to occur with machines that are loaned or rented to someone who has not read the operator's manual and is not familiar with a PTO ditcher.
- Install and secure all guards and shields before starting or operating. The driveline guard, tractor and ditcher shields should be used and maintained in good working condition. They should be inspected carefully, at least daily, for missing shields or guards. Missing, broken or worn items must be replaced at once to reduce the possibility of injury from thrown objects or entanglement.
- The area between the tractor and the PTO driven ditcher is a **DANGER** zone. The driveline must be attached securely to the tractor and the ditcher. Don't attach the driveline with a longer bolt or any other device than those which are original equipment on the ditcher. Modified equipment can only catch loose clothing, boot-laces or a pant cuff while spinning rapidly and possibly cause serious bodily injury.
- Make sure the driveline guard can rotate independent of the shaft a full rotation and can telescope freely.
- Make sure the driveline retaining chain is in place and secured around the ditcher frame brace tubing.

- Make sure the driveline clutch shear bolt is in place and that proper replacement bolts are readily available.
- Make sure front of tractor is properly weighted for safe steering control and operation.
- Clear the area of people, especially children, before starting the unit.
- Disengage power takeoff (PTO) and place transmission into neutral before attempting to start engine.
- Always stop the tractor, disengage the PTO, set brake, shut off the tractor engine, remove the ignition key, lower implement to the ground and allow ditcher blades to come to a complete stop before dismounting tractor. Never leave the ditcher unattended with the tractor running.
- Never place hands or feet under ditcher with the tractor engine on before you are sure all motion has stopped. Stay clear of all moving parts.
- Do not reach or place yourself under equipment until it is blocked securely.
- Do not allow riders on the ditcher or tractor at any time. There is no safe place for any riders.
- Do not operate unless all people, livestock and pets are several hundred feet away to prevent injury by thrown objects. Never direct discharge toward anyone.
- Never operate tractor and ditcher under trees with low hanging limbs. Operators can be knocked off the tractor and then run over by the rotating blades.
- The rotating parts of this machine have been designed and tested for rugged use. However, they could fail upon impact with heavy, solid objects such as steel or concrete. Such impact could cause the broken objects to be thrown outward at high velocities. To reduce the possibility of property damage, serious injury, or even death, never allow the cutting blades to contact such obstacles.
- Stop ditcher and tractor immediately upon striking an obstruction. Turn the engine off, remove key, inspect and repair any damage before resuming operation.
- Stay alert for uneven terrain, rocks and roots in the terrain and other hidden hazards.
- Keep away from drop-offs and hazards that could cause roll over.



Be Extra Cautious
around Moving Machinery!

SERVICE/MAINTENANCE

- Good maintenance is your responsibility. Poor maintenance is an invitation to trouble.
- Before working on this machine stop the tractor, set the brakes, disengage the PTO and power drives, shut off the engine and remove the ignition key.
- Never work under equipment unless it is securely blocked.
- Frequently check ditcher blades. They should be free of nicks and cracks and securely fastened.
- Periodically tighten all bolts and nuts and check that all cotter pins are properly installed to ensure unit is in a safe condition.
- When completing a maintenance or service function, make sure all safety shields and guards are installed before placing unit in service.
- Always use the proper tools or equipment for the job.
- After servicing, be sure all tools, parts and service equipment are removed from the ditcher.
- Do not allow debris, grease or oil to build up on any part of the machine.
- Where replacement parts are necessary for periodic maintenance and servicing, genuine factory replacement parts must be used to restore your ditcher to original specifications. W&A Manufacturing Company will not be responsible for injuries or damages caused by the use of unapproved parts and/or accessories.
- Never use machine until all guards and safety devices are securely in place.

STORAGE

- Following operation, or when unhooking the ditcher, stop the tractor, set the brakes, disengage the PTO, shut off the engine and remove the ignition keys.
- Do not allow the driveline to rest on the ground. Hang it on the hook provided. Rust and mud may interfere with the driveline locking device.
- Store the unit in an area away from human activity.
- Do not allow children to play on or around the stored unit.

SAFETY SIGNS

- Keep safety signs clean and legible at all times.
- Replace safety signs that are missing or have become illegible.
- Replaced parts that displayed a safety sign should also display the current sign.
- Safety signs are available from your dealer or W & A Manufacturing Company.



A. DANGER - Rotating Driveline Sign
Number 461082



B. DANGER - Guard Missing Sign
Number 461083
(Inside on Shaft)

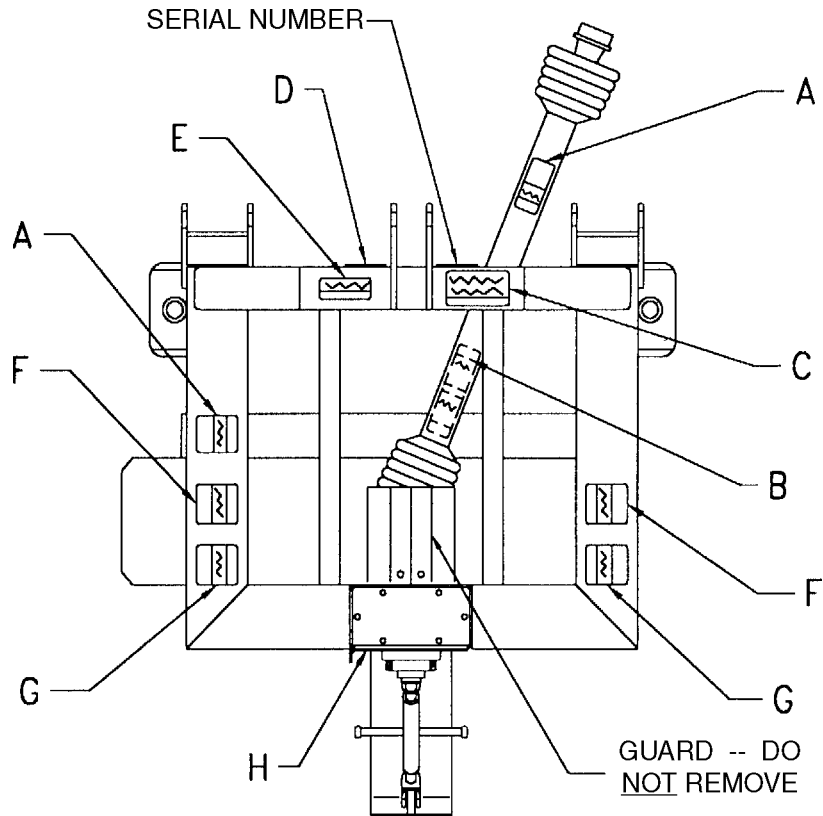

C. WARNING - Operator's Manual Sign
Number 461089

SAFETY SIGNS

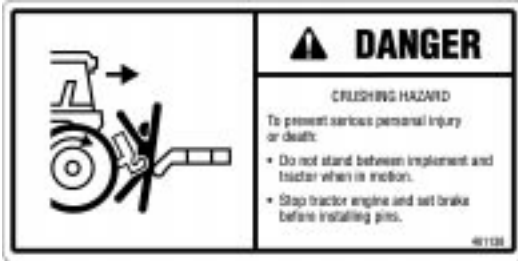

D. DANGER - Crushing Hazard
Sign Number 461138



E. WARNING - PTO Speed
Sign Number 461084



F. DANGER - Rotating Blades
Sign Number 461085



G. DANGER - Thrown Object Hazard. Sign Number 461087

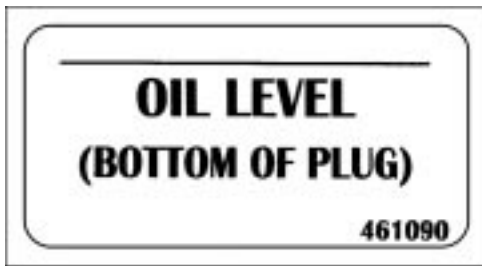

H. OIL LEVEL - Sign Number 461090
(Line level with bottom of plug)

- Keep safety signs clean and legible at all times.
- Replace safety signs that are missing or have become illegible.
- Replaced parts that displayed a safety sign should also display the current sign.
- Safety signs are available from your dealer or W & A Manufacturing Company. Phone (870) 534-7420

SPECIFICATIONS

The Model 360 and Model 370 Power Ditchers are connected to the tractor PTO shaft by means of a shielded protrusion free slide collar. The driveline shield is non-rotating for increased life and complies with safety standards worldwide. The shear bolt clutch protects the driveline against machine blockages. The 1-15/16" diameter high carbon steel in-put and out-put shafts are connected by a #100 roller chain with a continuous oil bath lubrication. The drive system rotates on four triple seal greaseable ball bearings. The Model 360 has a 18 tooth in-put sprocket and a 18 tooth out-put sprocket with a cutter head speed of 540 RPM. The Model 370 has a 14 tooth in-put sprocket and a 22 tooth out-put sprocket with a cutter head speed of 630 RPM. The entire chain drive system is housed inside a 12" x 6" structural steel case, easily accessible by two (2) removable rear plates. The dirt shielded cutter drum has four (4) high carbon plow steel blades with a cutting diameter adjustable from 17" to 19".

The Model 360 is designed for use on tractor with 65 to 110 horsepower and 540 RPM Power Take Off. The Model 370 is designed for tractors with 80 to 160 horsepower and 1000 RPM Power Take Off. **Use on tractors with more horsepower could cause high maintenance cost or personal injury.**

	Model 360	Model 370
HORSEPOWER RECOMMENDATION	For use on tractors with 540 RPM PTO from 50 to 110 horsepower.	For use on tractors with 1000 RPM PTO from 80 to 160 horsepower.
TRACTOR HITCH	Category II or III Standard or Quick Hitch	
CUTTER HEAD	Adjustable 17" to 19" diameter. Features four (4) replaceable high carbon steel blades. Rotates at 540 RPM	Rotates at 630 RPM
CHAIN DRIVE	Heavy-duty, endless #100 roller chain. Shafts 1-15/16" diameter high-carbon.	
	Top sprockets have 18 teeth and bottom sprockets have 18 teeth.	Top sprockets have 14 teeth and bottom sprockets have 22 teeth.
CLUTCH SHEAR BOLT	M10 x 60-8.8 Hex head cap screw	
UNIVERSAL DRIVE SHAFT	1-3/8" 6 Spline. Quick coupler connects to 540 RPM tractor PTO shaft. Shaft is telescoping & fully shielded.	1-3/8" - 21 Spline or 1-3/4" - 20 Quick coupler connects to 1000 RPM tractor PTO shaft. Shaft is telescoping & fully shielded.
CHAIN HOUSING	12" X 6" X 1/4" structural tubing welded into rigid, one piece, all welded main frame.	

Because of our continuing effort to improve our products, we reserve the right to change design and specifications without notice.

ADJUSTMENTS & OPERATION



BEFORE ATTACHING YOUR DITCHER, STOP THE TRACTOR AND DISENGAGE THE PTO AND POWER DRIVE.



INSTALL PROPER BALLAST ON FRONT OF TRACTOR TO INSURE SAFE AND PROPER STEERING AT ALL TIMES.

1. Make all adjustments on a flat level surface.
2. Attach ditcher to tractor three point linkage.



EXTREME CARE SHOULD BE USED WHEN HITCHING DITCHER TO TRACTOR TO PREVENT INJURY TO HANDS OR FINGERS. DO NOT STAND BETWEEN THE DITCHER AND TRACTOR WHEN IT IS IN MOTION. STOP TRACTOR ENGINE AND SET BRAKE BEFORE INSTALLING PINS.

3. The yoke of the driveline is then attached to the PTO shaft of the tractor. Be sure the slide collar snaps into place to secure the shaft and check that the tractor master safety shield is in place.



MAKE SURE THE DRIVELINE GUARD CAN ROTATE INDEPENDENT OF THE SHAFT A FULL ROTATION AND TELESCOPE FREELY.



MAKE SURE THE SAFETY CHAIN IS ATTACHED TO THE DRIVELINE AND SECURED AROUND THE LEFT SIDE 2" SQUARE TUBING FRAME BRACE.

4. The tractor's top link should be extended or retracted until the ditcher chain housing is vertical when lowered to the operating position. The driveline must have an equal offset in each joint.
5. If the tractor is equipped with a float position on the three point lift, this should be used.

This will allow the adjustable skid shoe to control the depth of cut. To get a deeper ditch, raise the skid shoe by means of the adjusting crank at the rear of the chain housing up to 15" deep. To get a more shallow ditch, lower the skid shoe by means of the adjusting crank.

6. The cutting diameter may be adjusted by moving the location of the blades on the cutter drum. Location in the inside set of holes will give a 17" diameter cut. Locating the blades in the outside holes will give a 19" diameter cut. Be sure all blades are in the same set of holes and all bolts are tightened securely.
7. Lift the ditcher from the ground and raise the parking stands securing them with the pins provided.
8. Raise and lower the ditcher slowly to check engagement of the drive shaft. Make sure your three-point hitch and drawbar are correctly positioned so neither interferes with the driveline.



BEFORE OPERATING YOUR PTO DITCHER THOROUGHLY READ AND UNDERSTAND THE SAFETY SECTION OF THIS MANUAL.

9. The ditcher should be lowered to just above the ground and the PTO engaged. The PTO should not be engaged with the blades resting on the ground. This sudden shock could result in broken shear bolts, chain, or driveline. After the cutter head has started rotating, set the engine speed for 540 or 1000 RPM PTO speed. Start the forward motion of the tractor and lower the ditcher into the ground. Forward speed and depth of cut should be matched to soil conditions.

When backing or turning, the ditcher should be raised to clear the ground. The ditcher should never be raised to maximum height with the PTO engaged.



DISENGAGE THE PTO AND STOP BLADE ROTATION IF BYSTANDERS COME WITHIN SEVERAL HUNDRED FEET.

SAFETY FIRST



LUBRICATION



BEFORE WORKING ON THIS MACHINE STOP THE TRACTOR, SET THE BRAKES, DISENGAGE THE PTO, SHUT OFF THE ENGINE AND REMOVE THE IGNITION KEY.

CHAIN HOUSING:

Gear oil has been added to the chain case during final assembly. Recheck lubricant level before initial operation of the ditcher. The fluid level should be checked from time to time. With the machine level, remove the ¼" plug (A) located at the bottom rear bearing plate. The gear oil should be level with the bottom of the ¼" plug hole at all times.

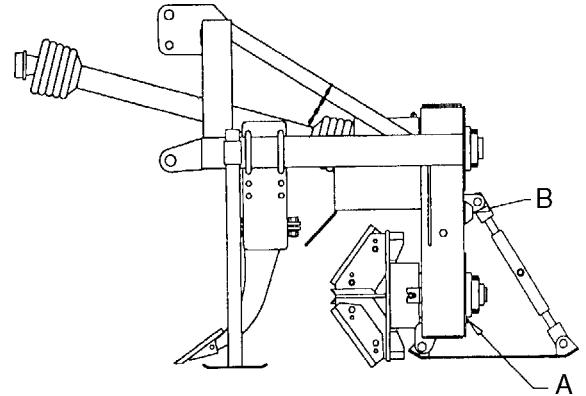

To add gear oil remove the ½" vented plug (B) on the inspection cover. Add HD 85W-140 gear oil until seen at the bottom of the ¼" plug hole. **DO NOT FILL ABOVE BOTTOM OF PLUG.** Reassemble both pipe plugs.

DRIVELINE & BEARINGS:

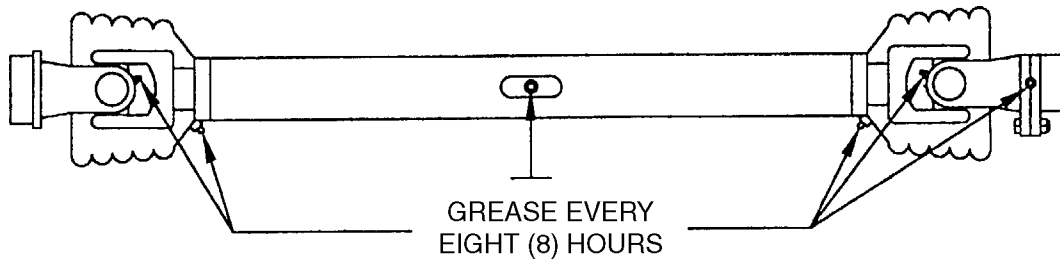

The driveline and bearings should be lubricated with a good grade of grease every 8 hours of operation. There are six (6) driveline grease fittings as shown in the illustration and four bearing grease fittings.



WHEN COMPLETING A MAINTENANCE OR SERVICE FUNCTION, MAKE SURE ALL SAFETY SHIELDS AND GUARDS ARE INSTALLED BEFORE PLACING UNIT IN SERVICE.

MAINTENANCE & SERVICE



BEFORE WORKING ON THIS MACHINE STOP THE TRACTOR, SET THE BRAKES, DISENGAGE THE PTO, SHUT OFF THE ENGINE AND REMOVE THE IGNITION KEY.

Daily or every eight (8) hours of operation:

- Visually check chain housing for oil leaks.
- Inspect for loose or damaged blades.
- Visually inspect entire Power Ditcher for worn, loose, damaged or missing parts.
- Grease 1-15/16" chain housing bearings.
- Grease driveline. Use a good grade of clean grease. (See Lubrication Page 13)
- Check chain housing oil level. Use a good grade of clean HD 85W-140 gear lube when adding oil. (See Lubrication Page 13)

Every Season or every 250 hours of operation:

- Inspect for worn or damaged parts. Replace if needed.
- Remove oil from chain housing and flush case with kerosene or diesel fuel to remove contamination. Replace oil with a good grade of clean HD 85W-140 gear lube.
- Inspect chain, sprockets and bearings for wear. Replace if needed.
- Inspect universal drive shaft for worn or damaged parts. Replace if needed.
- Inspect blades for wear, replacing blades if worn or damaged.
- Thoroughly inspect entire Power Ditcher for missing, worn or damaged parts. Repair or replace these parts during the "off-season" to assure dependable, trouble-free performance during the season of use.
- Review safety regulations and rules with all operators and personnel.

Chain Adjustment

The chain adjusting bolt is located on the right hand side of chain housing. Tighten to "finger tight" in order to remove excess chain slack. Do not over tighten.

Secure by tightening jam nut.



WHEN COMPLETING A MAINTENANCE OR SERVICE FUNCTION, MAKE SURE ALL SAFETY SHIELDS AND GUARDS ARE INSTALLED BEFORE PLACING UNIT IN SERVICE.