

RIGID LEVEL BANDER

Model Nos. 3660 - 3661

Table of Contents

Click the Level Bander model number below for a
Parts Manual for each model.

3660 - 8 Row 30" Rigid Level Bander

- Pages 3 - 8

3661 - 8 Row 38" Rigid Level Bander

- Pages 9 - 15



BUSTER LEVEL BANDER RIGID BAR

Model No. 3660 -- 8 @ 30" Row

3660 - 8 Row 30" Rigid Level Bander

REEL

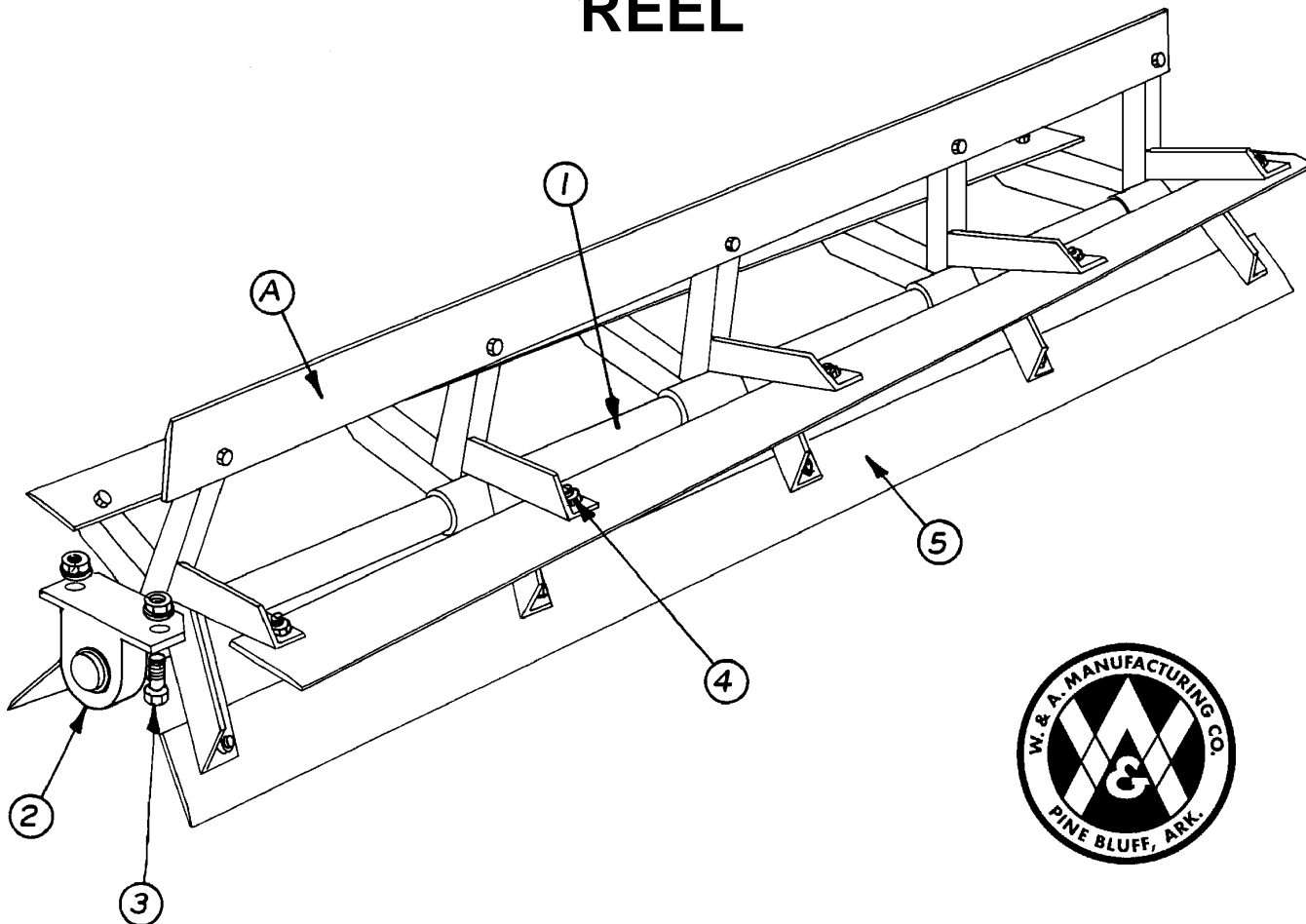

ITEM NO.	PART NO.	WT. LBS.	DESCRIPTION	QTY. REQ'D FOR 1 MACHINE
A	770022	350	Spiral 110" Reel Complete w/Bearings	2
1	301068	191	1-15/16" x 118" Shaft Only w/7 Support Brackets	2
2	482101	4	1-15/16" Pillow Block & Bearing Complete	4
-	481215	1	1-15/16" Bearing w/Lock Collar	4
-	480006	3	Pillow Block for 1-15/16" Bearing	4
3	411562	¼	Hex Bolt -- 5/8" x 2½" NC - Gr. 5 - Zinc	8
-	410009	-	Hex Nut -- 5/8" NC - Gr 2 - Zinc	8
-	413010	-	Flat Washer -- 5/8" - Zinc	8
4	411211	¼	Hex Bolt -- 5/8" x 1¼" NC - Gr. 2 - Zinc	70
-	410009	-	Lock Nut -- 5/8" NC - Gr 2 - Zinc	70
5	202180	32	Spiral Pulvamer Blade x 110"(9/32" x 4" x 110")	10

3660 - 8 Row 30" Rigid Level Bander

BOLT-ON SHANK HOLDERS

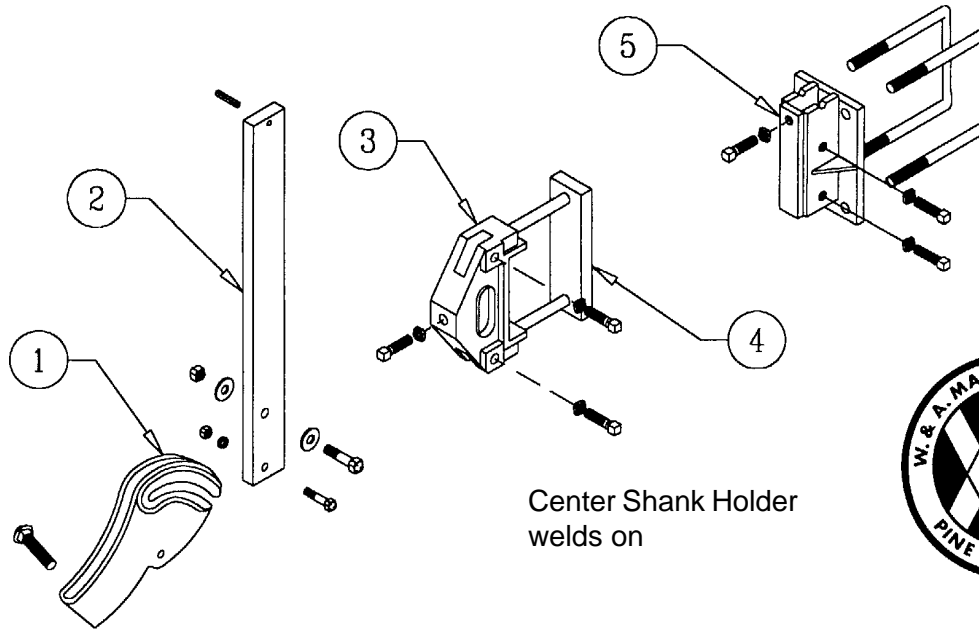

Center Shank Holder
welds on



<u>ITEM NO.</u>	<u>PART NO.</u>	<u>WT. LBS.</u>	<u>DESCRIPTION</u>	<u>QTY. REQ.</u>
1	479075	6½	Friction Trip Foot	9
-	411549	-	Hex Bolt -- 1/2" x 2½" NC - Gr. 5 - Zinc.....	9
-	411563	½	Hex Bolt -- 5/8" x 3" NC - Gr. 5 - Zinc.....	9
-	411794	½	Carriage Bolt -- 3/4" x 3½" NC - Gr. 5 - Zinc	9
-	410009	-	Lock Nut -- 5/8" NC - Gr 2 - Zinc	9
-	410012	-	Lock Nut -- 3/4" NC - Gr 2 - Zinc	9
-	412008	-	Hex Nut -- 1/2" - 13 - Gr. 2 - Zinc	9
-	413056	-	Flat Washer, Heavy -- 5/8" - Zinc.....	18
-	413058	-	Flat Washer, Heavy -- 3/4" - Zinc.....	18
-	413508	-	Lock Washer -- 1/2" - Zinc	9
2	204210	25	Vertical Shank C1080	9
-	416120	-	Roll Pin -- 3/8" x 2" - Zinc	9
3	479069	13½	Bolt-On Shank Holder - 7" Tool Bar	6
-	414828	-	Square Head Set Screw -- 5/8" x 1-3/4".....	18
-	412310	-	Square Nut -- 5/8" - 11 - Gr. 2 - Zinc.....	18
-	412410	-	Jam Nut -- 5/8" - 11 - Gr. 2 - Zinc	18
4	204274	9	Backing Plate for Bolt-On Shank Holder - 7"	6
-	411602	1¼	Hex Bolt -- 3/4" x 9" NC - Gr. 5 - Zinc.....	12
-	412012	-	Hex Nut -- 3/4" - 10 - Gr. 2 - Zinc.....	12
-	413512	-	Lock Washer -- 3/4" - Zinc	12
5	302036	19½	Center Bolt-On Shank Holder	2
-	415004	2½	3/4" Sq. U-Bolt x 7" x 9" Leg	4
-	412012	-	Hex Nut -- 3/4" - 10 - Gr. 2 - Zinc.....	8
-	413512	-	Lock Washer -- 3/4" - Zinc.....	8
-	414828	-	Square Head Set Screw -- 5/8" x 1¾"	9
-	412410	-	Jam Nut -- 5/8" - 11 - Gr 2 - Zinc	9

NOTE: On 8@ 30" Row Rigid Buster Level Bander -- ONE Shank Holder is welded on frame.

3660 - 8 Row 30" Rigid Level Bander

HITCH ASSEMBLY

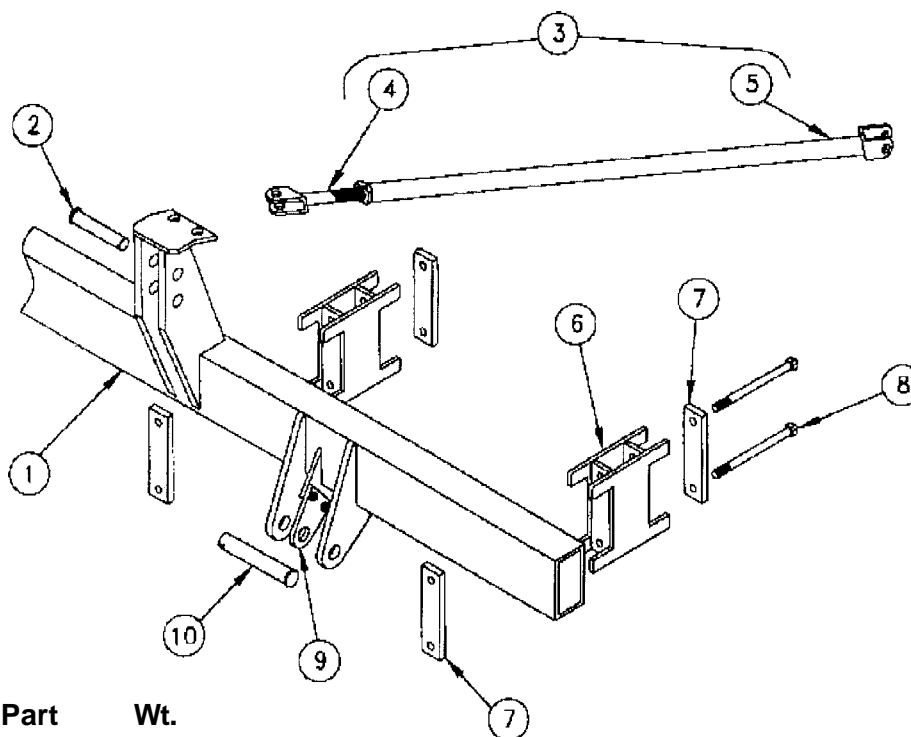

Item No.	Part No.	Wt. Lbs.	Description	Qty. Req'd. for 1 Machine
1	302005	324	8 Row Hitch -- Cat III & III N(4" x 7" x 102" Main Tube).....	1
2	200853	2	Hardened Top Link Pin -- 1¼" x 5-15/16" - Zinc	1
-	416207	-	Klik Pin -- 7/16" - Zinc	1
3	773666	21½	Adjusting Arm Assembly	2
-	416659	.70	Clevis Pin -- 1" x 2-21/32" - Zinc	4
-	416309	-	Rue Ring Cotter Pin 1" - Zinc	4
4	300381	5¼	Turnbuckle Bottom (Rod)	2
5	301602	16¼	Turnbuckle Body (65" Pipe)	2
6	302014	25	5" Spacer Block -- Top Leveling Stacker	4
7	203960	5	Backing Plate -- Top Leveling Stacker	8
-	411598	½	Hex Bolt -- 3/4" x 6½" NC - Gr 5 - Zinc	8
-	412012	-	Hex Nut -- 3/4" - 10 - Gr 2 - Zinc	8
-	413512	-	Lock Washer -- 3/4" - Zinc	8
8	411604	1¼	Hex Bolt -- 3/4" x 10" NC - Gr 5 - Zinc	8
-	412012	-	Hex Nut -- 3/4" - 10 - Gr 2 - Zinc	8
-	413512	-	Lock Washer -- 3/4" - Zinc	8
9	204117	3	Hitch Center Pull Plate	2
-	411214	¼	Hex Bolt -- 5/8" x 2" NC - Gr 2 - Zinc	4
-	412010	-	Hex Nut -- 5/8" - 11 - Gr 2 - Zinc	4
-	413510	-	Lock Washer -- 5/8" - Zinc	4
10	200876	4¼	Hardened Pull Pin -- 1-7/16" x 8-3/8" - Zinc	2
-	416207	-	Klik Pin -- 7/16" - Zinc	2

3660 - 8 Row 30" Rigid Level Bander

ROLLING BASKETS

1 1/4" Shaft and Bearings

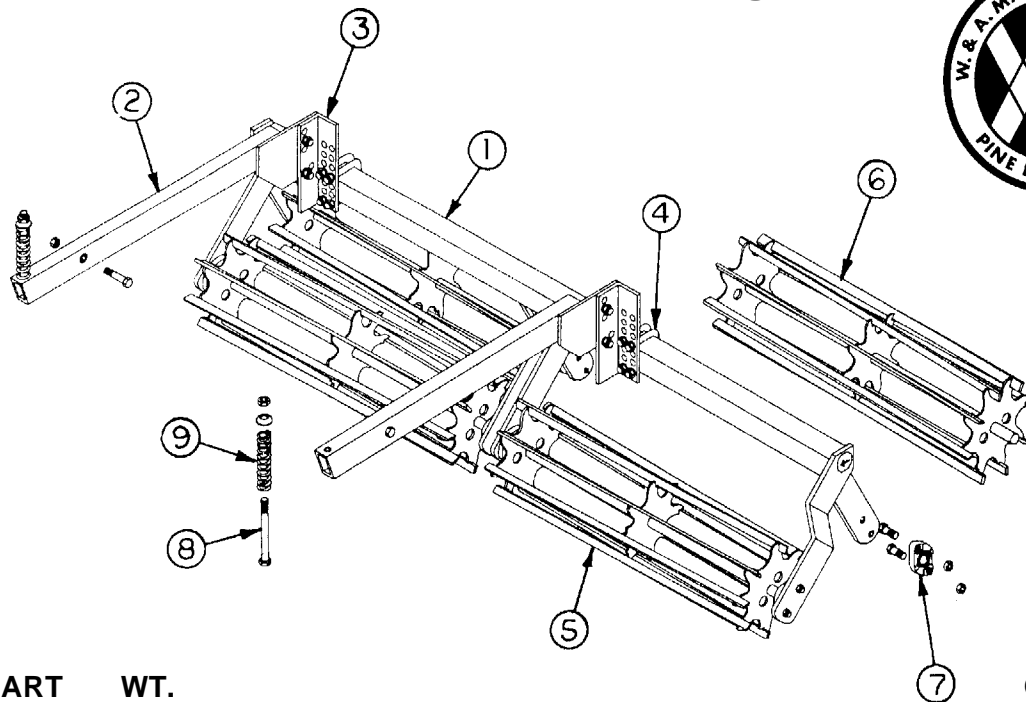

ITEM NO.	PART NO.	WT. LBS.	DESCRIPTION	QTY. REQ'D FOR 1 MACHINE
1	301954	100	Four Basket Frame -- 1 1/4" Brg. (2 row) (Shown)	-
-	301955	150	Six Basket Frame 38" -- 1 1/4" Brg. (3 row)	2
2	301290	20 1/2	Arm -- Rolling Baskets	6
-	411551	-	Hex Bolt -- 1/2" x 3" NC - Gr 5 - Zinc	6
-	410008	-	Lock Nut -- 1/2" NC - Zinc	42
3	202729	5 1/2	Connecting Angle - Rolling Baskets	6
-	411545	-	Hex Bolt -- 1/2" x 1 1/2" NC - Gr 5 - Zinc	12
4	415108	1/2	1/2" U-Bolt x 2 1/2" x 4" Leg - Grade 5	12
5	301948	41 1/4	Front Rolling Basket Only -- 1 1/4" Shaft	6
-	202749	2.7	Blade Only for Front Rolling Baskets	-
6	301949	41 1/4	Rear Rolling Basket Only -- 1 1/4" Shaft	6
-	202750	2.7	Blade Only for Rear Rolling Baskets	-
7	482024	2	1 1/4" Cast Flange Bearing Assm RB	24
-	481288	-	1 1/4" Bearing Only w/Lock Collar RB	-
-	411534	-	Hex Bolt -- 7/16" x 1 1/2" NC - Gr 5 - Zinc(Outside Bearings)	16
-	204145	-	Bearing Spacer(Inside Bearings)	8
-	411539	-	Hex Bolt -- 7/16" x 3 1/2" NC - Gr 5 - Zinc(Inside Bearings)	16
-	410007	-	Lock Nut -- 7/16" NC - Zinc	32
8	411237	1	Hex Bolt -- 5/8" x 8" NC - Gr 2 - Zinc	6
-	200412	-	Formed Head Holder	6
-	410009	-	Lock Nut -- 5/8" NC - Gr 2 - Zinc	6
-	202350	-	Cup Washer for Spring	6
9	471006	1 1/2	Compression Spring	6
N/I	302171	184	Basket Frame	1
N/I	204480	21 1/2	Connecting Channel	6

3660 - 8 Row 30" Rigid Level Bander

RATCHET ADJ. GAUGE WHEELS

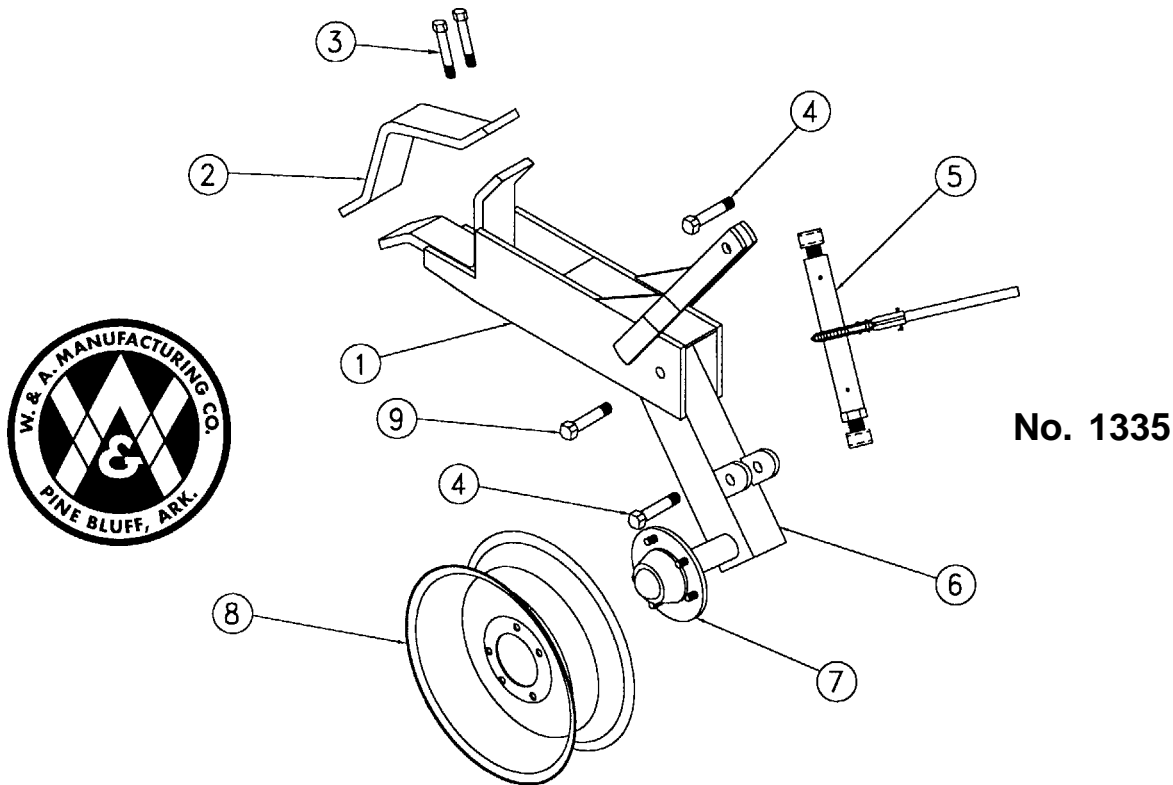

Item No.	Part No.	Wt. Lbs.	Description	Qty. Req'd. for 1 Assembly
1	301611	60	Holder -- Gauge Wheels	1
2	202320	10	Backing Clamp for 7" Sq. Bar	1
3	411565	¼	Hex Bolt -- 5/8" x 3½" NC - Gr 5 - Zinc	4
-	412010	-	Hex Nut -- 5/8" - 11 - Gr 2 - Zinc	4
-	413510	-	Lock Washer -- 5/8" - Zinc	4
4	411251	½	Hex Bolt -- 3/4" x 4" NC - Gr 2 - Zinc	2
-	412012	-	Hex Nut -- 3/4" - 10 - Gr 2 - Zinc	2
-	413512	-	Lock Washer -- 3/4" - Zinc	2
5	302025	11½	Ratchet Crank Assembly	1
6	301605	34	RH Leg w/Hub -- #1335 Gauge Wheel	1
-	301606	34	LH Leg w/Hub -- #1335 Gauge Wheel	1
7	491119	11	5 Hole Hub Complete - Q-719	1
-	491007	9¾	Hub w/Cups Only - Q-719	1
-	481205	¼	Cone - Q809 & Q719 - LM67048	1
-	496010	-	Outer Cup - Q809 & Q719 - LM67010	1
-	481204	¼	Cone - Q809 & Q719 - LM48548	1
-	496011	-	Inner Cup - Q809 & Q719 - LM48510	1
-	497010	-	Grease Seal - Q719 - CR 15190	1
-	490006	¼	Hub Cap - Q809 & Q719	1
-	490015	-	1/2" NF Lug Nut	5
-	490017	-	Drive-In Hub Bolt - Q719	5
-	412164	-	Slotted Nut -- 7/8" - 14 Spindle	1
-	490034	-	Spindle Washer -- 7/8" - Q875/Q809/Q719	1
8	493007	17	15" x 5" x 5 Hole Wheel	1
9	411254	¾	Hex Bolt -- 3/4" x 5" NC - Gr 2 - Zinc	1
-	412012	-	Hex Nut -- 3/4" - 10 - Gr 2 - Zinc	1
-	413512	-	Lock Washer -- 3/4" - Zinc	1

BUSTER LEVEL BANDER RIGID BAR

Model No. 3661 -- 8 @ 38" Row

3668 - 8 Row 38" Rigid Level Bander

REEL

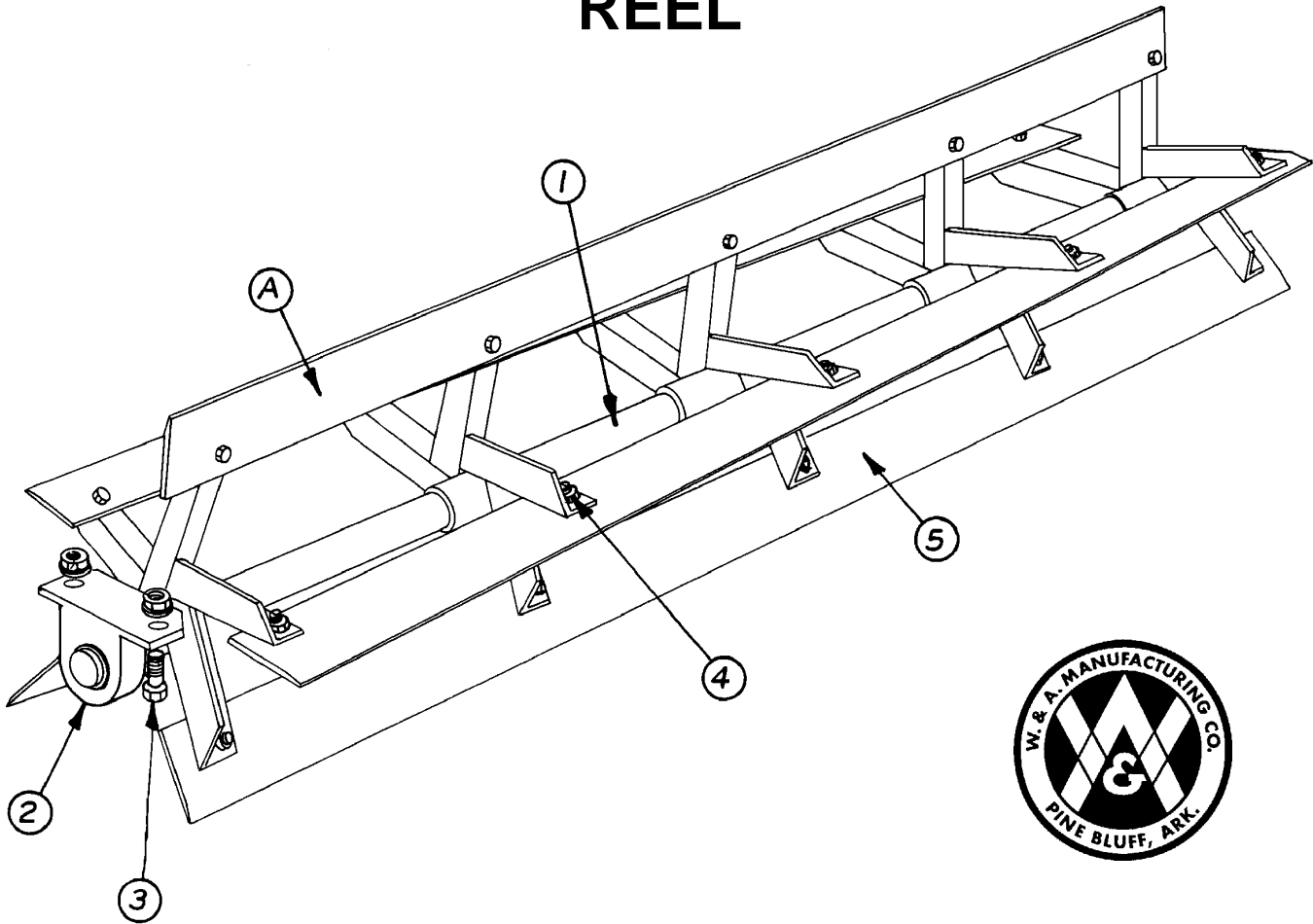

<u>ITEM NO.</u>	<u>PART NO.</u>	<u>WT. LBS.</u>	<u>DESCRIPTION</u>	<u>QTY. REQ'D FOR 1 MACHINE</u>
A	770020	235	Spiral 6 ft Reel Complete w/Bearings.....	4
1	300451	116	Spiral 77" Reel Shaft w/5 Support Brackets	4
2	482101	4	1-15/16" Pillow Block & Bearing Complete	8
-	481215	1	1-15/16" Bearing w/Lock Collar	-
-	480006	3	Pillow Block for 1-15/16" Bearing	-
3	411562	-	Hex Bolt -- 5/8" x 2-1/2" NC - Gr 5 - Zinc.....	16
-	410009	-	Lock Nut -- 5/8" NC - Gr 2 - Zinc	16
-	413010	-	Flat Washer -- 5/8" - Zinc	16
4	411211	-	Hex Bolt -- 5/8" x 1-1/4" NC - Gr 2 - Zinc.....	100
-	410009	-	Lock Nut -- 5/8" NC - Gr 2 - Zinc	100
5	200539	20	Spiral Pulvamer Blade x 72"	20

3668 - 8 Row 38" Rigid Level Bander

BOLT-ON SHANK HOLDERS

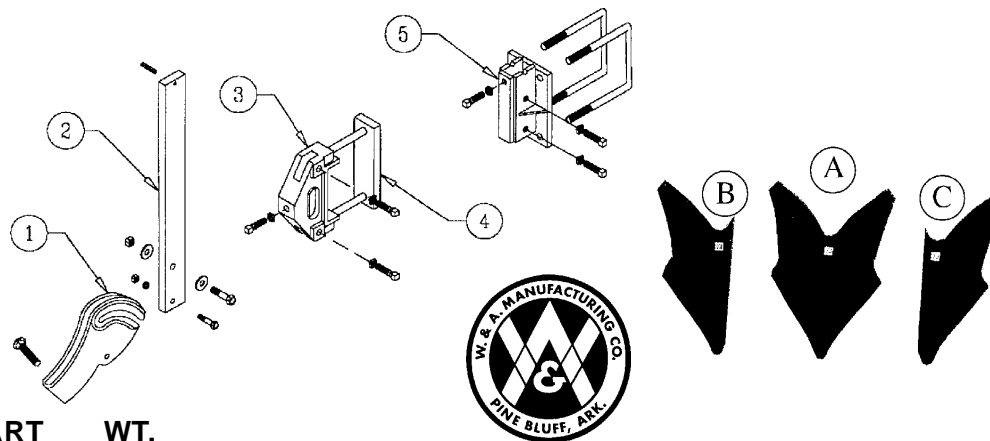

<u>ITEM NO.</u>	<u>PART NO.</u>	<u>WT. LBS.</u>	<u>DESCRIPTION</u>	<u>QTY. REQ'D FOR 1 MACHINE</u>
1	479075	6½	Friction Trip Foot	9
-	411549	-	Hex Bolt -- 1/2" x 2½" NC - Gr. 5 - Zinc.....	9
-	411563	½	Hex Bolt -- 5/8" x 3" NC - Gr. 5 - Zinc.....	9
-	411794	½	Carriage Bolt -- 3/4" x 3½" NC - Gr. 5 - Zinc	9
-	410009	-	Lock Nut -- 5/8" NC - Gr 2 - Zinc	9
-	410012	-	Lock Nut -- 3/4" NC - Gr 2 - Zinc	9
-	412008	-	Hex Nut -- 1/2" - 13 - Gr. 2 - Zinc	9
-	413056	-	Flat Washer, Heavy -- 5/8" - Zinc	18
-	413058	-	Flat Washer, Heavy -- 3/4" - Zinc	18
-	413508	-	Lock Washer -- 1/2" - Zinc.....	9
2	204210	25	Vertical Shank C1080	5
-	416120	-	Roll Pin -- 3/8" x 2" - Zinc.....	9
3	479069	13½	Bolt-On Shank Holder - 7" Tool Bar	6
-	414828	-	Square Head Set Screw -- 5/8" x 1¾"	18
-	412310	-	Square Nut -- 5/8" - 11 - Gr. 2 - Zinc	18
-	412410	-	Jam Nut -- 5/8" - 11 - Gr. 2 - Zinc	18
4	204274	9	Backing Plate for Bolt-On Shank Holder - 7"	6
-	411601	1¼	Hex Bolt -- 3/4" x 8½" NC - Gr. 5 - Zinc	12
-	412012	-	Hex Nut -- 3/4" - 10 - Gr. 2 - Zinc	12
-	413512	-	Lock Washer -- 3/4" - Zinc.....	12
5	302036	19½	Center Bolt-On Shank Holder.....	2
-	415004	2½	3/4" Sq. U-Bolt x 7" x 9" Leg	4
-	412012	-	Hex Nut -- 3/4" - 10 - Gr. 2 - Zinc	8
-	413512	-	Lock Washer -- 3/4" - Zinc.....	8
-	414828	-	Square Head Set Screw -- 5/8" x 1¾"	9
-	412410	-	Jam Nut -- 5/8" - 11 - Gr 2 - Zinc.....	9
N/I	302002	28	3" Offset Shank – RH	2
N/I	302003	28	3" Offset Shank – LH.....	2
A	474031	7¼	#11N Furrower.....(11" Top Width)	7
B	204215		#11N End Furrower -- RH.....	1
C	204216		#11N End Furrower -- LH	1

NOTE: On 8@ 38" Row Rigid Buster Level Bander -- ONE Shank Holder is welded on frame.

3668 - 8 Row 38" Rigid Level Bander

HITCH ASSEMBLY

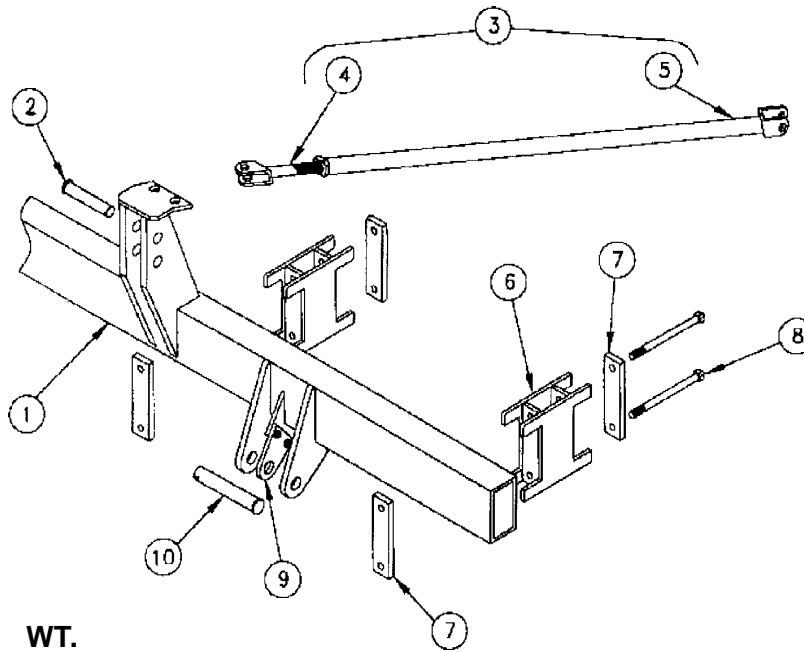

<u>ITEM NO.</u>	<u>PART NO.</u>	<u>WT. LBS.</u>	<u>DESCRIPTION</u>	<u>QTY. REQ'D FOR 1 MACHINE</u>
1	302019	349	Hitch -- Cat III & III N (4" x 7" x 114" Main Tube)	1
2	416698	2	1 1/4" Top Link Pin - Zinc	1
-	416207	-	Klik Pin -- 7/16" - Zinc	1
3	773666	21 1/2	Adjusting Arm Assembly	2
-	416659	.70	Clevis Pin -- 1" x 2-21/32" - Zinc	4
-	416309	-	Rue Ring Cotter Pin 1" - Zinc	4
4	300381	5 1/4	Turnbuckle Bottom (Rod)	2
5	301602	16 1/4	Turnbuckle Body (65" Pipe)	2
6	302014	25	5" Spacer Block -- Top Leveling Stacker	4
7	203960	5	Backing Plate -- Top Leveling Stacker	8
-	411598	1/2	Hex Bolt -- 3/4" x 6 1/2" NC - Gr 5 - Zinc	8
-	412012	-	Hex Nut -- 3/4" - 10 - Gr 2 - Zinc	8
-	413512	-	Lock Washer -- 3/4" - Zinc	8
8	411604	1 1/4	Hex Bolt -- 3/4" x 10" NC - Gr 5 - Zinc	8
-	412012	-	Hex Nut -- 3/4" - 10 - Gr 2 - Zinc	8
-	413512	-	Lock Washer -- 3/4" - Zinc	8
9	204117	3	Hitch Center Pull Plate	2
-	411214	1/4	Hex Bolt -- 5/8" x 2" NC - Gr 2 - Zinc	4
-	412010	-	Hex Nut -- 5/8" - 11 - Gr 2 - Zinc	4
-	413510	-	Lock Washer -- 5/8" - Zinc	4
10	300841	4 1/4	Hitch Pin -- 1-7/16" x 9"	2
-	416207	-	Klik Pin -- 7/16" - Zinc	2

3668 - 8 Row 38" Rigid Level Bander

ROLLING BASKETS

1 1/4" Shaft and Bearings

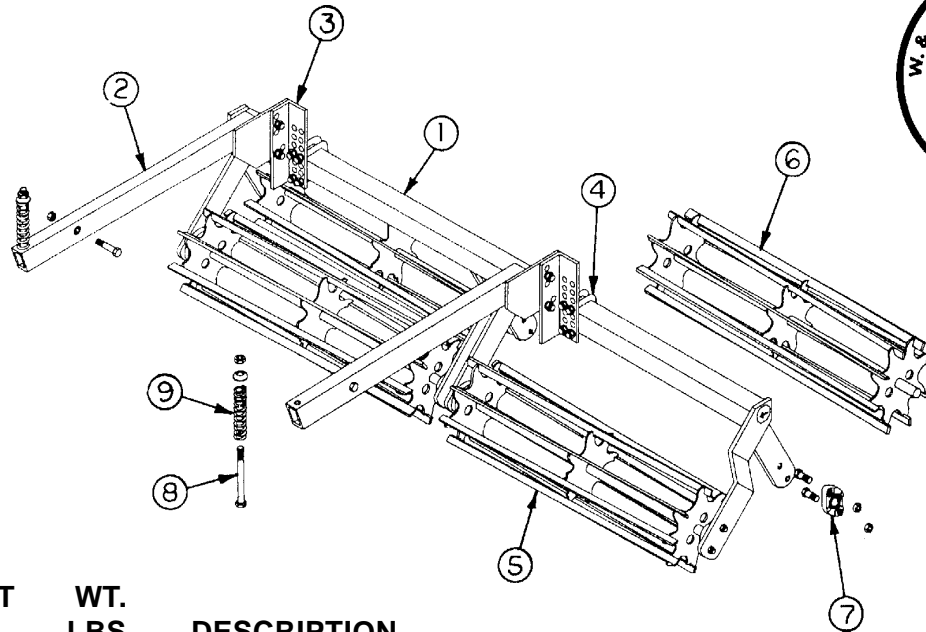

ITEM NO.	PART NO.	WT. LBS.	DESCRIPTION	QTY. REQ'D FOR 1 MACHINE
1	301954	100	Four Basket Frame -- 1 1/4" Brg. (2 row) (Shown)	2
-	301956	200	Eight Basket Frame -- 1 1/4" Brg. (4 row)	1
2	301290	20 1/2	Arm -- Rolling Baskets	7
-	411551	-	Hex Bolt -- 1/2" x 3" - Gr 5 - Zinc	7
-	410008	-	Lock Nut -- 1/2" - Zinc	49
3	202729	5 1/2	Connecting Angle - Rolling Baskets	7
-	411545	-	Hex Bolt -- 1/2" x 1 1/2" NC - Gr 5 - Zinc	14
4	415108	1/2	1/2" U-Bolt x 2 1/2" x 4" Leg - Grade 5	14
5	301948	41 1/4	Front Rolling Basket Only -- 1-1/4" Shaft	8
-	202749	2.7	Blade Only for Front Rolling Baskets	-
6	301949	41 1/4	Rear Rolling Basket Only -- 1-1/4" Shaft	8
-	202750	2.7	Blade Only for Rear Rolling Baskets	-
7	482024	2	1 1/4" Cast Flange Bearing Assm RB	32
-	481288	-	1 1/4" Bearing Only w/Lock Collar RB	-
-	411534	-	Hex Bolt -- 7/16" x 1 1/2" NC - Gr 5 - Zinc	24
-	204145	-	Bearing Spacer	10
-	411539	-	Hex Bolt -- 7/16" x 3 1/2" NC - Gr 5 - Zinc	20
-	410007	-	Lock Nut -- 7/16" NC - Zinc	32
8	411237	1	Hex Bolt -- 5/8" x 8" NC - Gr 2 - Zinc	7
-	200412	-	Formed Head Holder	7
-	410009	-	Lock Nut -- 5/8" NC - Gr 2 - Zinc	7
-	202350	-	Cup Washer for Spring	7
9	471006	1 1/2	Compression Spring	7
N/I	302168	402	Basket Frame	1
N/I	204480	21 1/2	Connecting Channel	8

3668 - 8 Row 38" Rigid Level Bander

RATCHET ADJ. GAUGE WHEELS

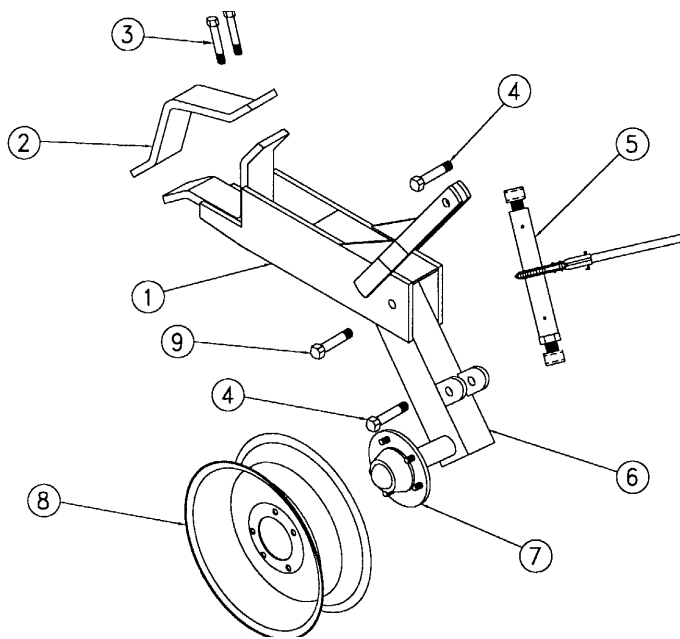

**No. 1338
& 1339**

<u>ITEM NO.</u>	<u>PART NO.</u>	<u>WT. LBS.</u>	<u>DESCRIPTION</u>	<u>QTY. REQ'D FOR 1 ASSEMBLY</u>
1	302225	60	Holder -- Gauge Wheels	1
2	203770	10	Backing Clamp for 7" Sq. Bar	1
3	411591	½	Hex Bolt -- 3/4" x 4" NC - Gr 5 - Zinc	4
-	412012	-	Hex Nut -- 3/4" - 10 - Gr 2 - Zinc	6
-	413512	-	Lock Washer -- 3/4" - Zinc	6
4	411591	½	Hex Bolt -- 3/4" x 4" NC - Gr 5 - Zinc	2
5	302025	11½	Ratchet Crank Assembly	1
6	302226	34¾	RH Leg w/Hub -- #1338 Gauge Wheel (Shown)	1
-	302227	34¾	LH Leg w/Hub -- #1338 Gauge Wheel	1
-	302228	38¾	RH 3" Offset Leg w/Hub -- #1339 Gauge Wheel	1
-	302229	38¾	LH 3" Offset Leg w/Hub -- #1339 Gauge Wheel	1
7	491119	11	5 Hole Hub Complete - Q-719	1
-	491007	9¾	Hub w/Cups Only - Q-719	1
-	481205	¼	Cone - Q809 & Q719 - LM67048	1
-	496010	-	Outer Cup - Q809 & Q719 - LM67010	1
-	481204	¼	Cone - Q809 & Q719 - LM48548	1
-	496011	-	Inner Cup - Q809 & Q719 - LM48510	1
-	497010	-	Grease Seal - Q719 - CR 15190	1
-	490006	¼	Hub Cap - Q809 & Q719	1
-	490015	-	1/2" NF Lug Nut	5
-	490017	-	Drive-In Hub Bolt - Q719	5
-	412164	-	Slotted Nut -- 7/8" - 14 Spindle	1
-	490034	-	Spindle Washer -- 7/8" - Q875/Q809/Q719	1
8	493007	17	15" x 5" x 5 Hole Wheel	1
9	411594	¾	Hex Bolt -- 3/4" x 5" NC - Gr 5 - Zinc	1
-	412012	-	Hex Nut -- 3/4" - 10 - Gr 2 - Zinc	1
-	413512	-	Lock Washer -- 3/4" - Zinc	1

3668 - 8 Row 38" Rigid Level Bander

4" BOLT-ON SHANK HOLDER

Optional

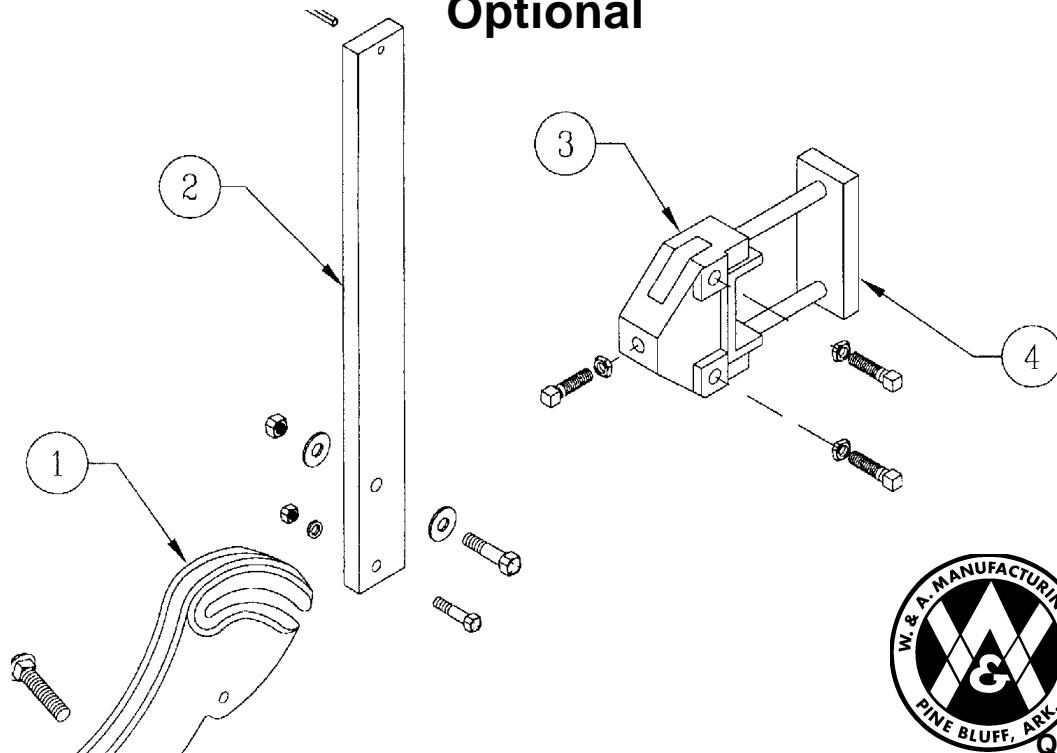

<u>ITEM NO.</u>	<u>PART NO.</u>	<u>WT. LBS.</u>	<u>DESCRIPTION</u>	<u>QTY. REQ'D FOR 1 MACHINE</u>
1	479075	6½	Friction Trip Foot	9
-	411549	-	Hex Bolt -- 1/2" x 2½" NC - Gr. 5 - Zinc	9
-	411563	½	Hex Bolt -- 5/8" x 3" NC - Gr. 5 - Zinc	9
-	411794	½	Carriage Bolt -- 3/4" x 3½" NC - Gr. 5 - Zinc	9
-	410009	-	Lock Nut -- 5/8" NC - Gr 2 - Zinc	9
-	410012	-	Lock Nut -- 3/4" NC - Gr 2 - Zinc	9
-	412008	-	Hex Nut -- 1/2" - 13 - Gr. 2 - Zinc	9
-	413056	-	Flat Washer, Heavy -- 5/8" - Zinc	18
-	413058	-	Flat Washer, Heavy -- 3/4" - Zinc	18
-	413508	-	Lock Washer -- 1/2" - Zinc	9
2	204210	25	Vertical Shank C1080	8
-	416120	-	Roll Pin -- 3/8" x 2" - Zinc	9
N/I	302002	28	3" Offset Shank -- RH (In Center)	1
3	479065	10¼	Bolt-On Shank Holder - 4" Tool Bar	9
-	414828	-	Square Head Set Screw -- 5/8" x 1¾"	27
-	412010	-	Hex Nut -- 5/8" - 11 - Gr 2 - Zinc	27
-	412410	-	Jam Nut -- 5/8" - 11 - Gr. 2 - Zinc	27
4	204275	6	Backing Plate for Bolt-On Shank Holder - 4"	9
-	411595	7¾	Hex Bolt -- 3/4" x 5½" - Gr. 5 - Zinc	18
-	412012	-	Hex Nut -- 3/4" - 10 - Gr. 2 - Zinc	18
-	413512	-	Lock Washer -- 3/4" - Zinc	18
N/I	474031	7¼	#11N Furrower	9