

W & A

RIGID CHOPPER-BEDDER

6 @ 38"/40" ROW -- 8 @ 38"/40" ROW -- 12 @ 30" ROW

NO. 3856 -- NO. 3858 -- NO. 3860

OPERATOR'S MANUAL

TO THE OWNER:

Congratulations on your purchase of a new W & A Chopper-Bedder. Your selection is an indication of your awareness of the need for intensive engineering, research, design, durability and dependability that has gone into their production.

Be sure to read all the instructions in this manual before placing the unit in use. Safety precautions along with adjustments should be learned and also taught to anyone who operates the machine. Remember, an implement which is properly maintained, adjusted, and safely operated saves time, labor and money.

After the operating season, thoroughly clean your chopper-bedder and inspect it. Preventive maintenance pays dividends. Your dealer has original equipment parts which assure proper fit and best performance.

Thank you for purchasing this W&A product.

For your convenience, please fill in the following:

Model: _____ Serial No. _____

Dealer Name: _____ Date Purchased _____



Quality Products from

W & A MANUFACTURING COMPANY

P.O. Box 5238, Pine Bluff, Arkansas 71611

Phone: (870) 534-7420

Fax: (800) 336-1318

Website: www.wamfgco.com

IMPORTANT SAFETY INSTRUCTIONS



This is the safety alert symbol. When you see this symbol on your machine or in this manual, be alert to the potential for personal injury or death. Follow the recommended precautions!

SAFETY PRECAUTIONS

- Before operating your Chopper-Bedder, thoroughly read and understand your operator's manual. If you do not understand any portion of the operator's manual, contact your dealer or W & A Manufacturing Company immediately.
- Train all new personnel and review instructions annually with existing workers. A person who has not read and understood all operating and safety instructions is not qualified to operate the machine. An untrained operator exposes himself and bystanders to possible serious injury or death.
- Clear the area of people, especially small children, before starting unit.
- Do not allow riders at any time.
- Place all controls in neutral, stop tractor engine, set park brake, and wait for all moving parts to stop before service, adjusting, repairing or unplugging.
- If safety signs are missing, illegible, or damaged, they should be replaced. See list of safety signs. Keep safety signs clean and legible.
- Furnish this manual to the new owner if the machine is sold.
- Inspect machine daily for worn parts, hydraulic leaks, frayed hoses, and make necessary repairs. Tighten all bolts and make sure all fasteners are in place.
- Un-authorized modifications to the machine may impair the function and/or safety and affect machine life. Make NO un-authorized modifications.
- Never stand between implement and tractor when hitching. Extreme care should be used to prevent injury to the hands or fingers. *Stop tractor engine and set brake before installing hitch pins.*
- Lower machine before servicing, adjusting, leaving, or storing machine.

TRANSPORTING

- Comply with all federal, state, and local laws for implement transport on public roads.
- Watch for obstructions overhead and to side while transporting.
- Do not drive at speeds over 20 MPH (33 kph). Always drive at a reasonable speed to maintain control for the situation at hand.
- When descending steep grades select a sufficiently low gear to maintain proper control with minimum braking. Do not “Free Wheel”. Always keep the tractor in gear.
- Never transport machine unless hydraulic systems are completely charged with hydraulic oil and transport safety locks are engaged.
- Raised wings can contact electric utility lines and overhead obstructions. Severe shock, injury, or death can result. Electrocutation can occur without direct contact. Drive carefully. Measure overall transport height and be sure of clearance.
- When transporting on a road or highway, use adequate warning symbols, reflectors, and SMV (slow moving vehicle) emblem as required. Do not transport at night or low light conditions.

OPERATIONS

- Never start or operate machine unless sitting on tractor seat.
- Always make sure hydraulic system is fully charged with oil before use. Failure to bleed the system of all air can cause folded wings or entire machine to drop suddenly.
- Make sure front of tractor is properly weighted for safe steering control and operation.
- Clear the area of people, especially small children, before starting the unit.
- Do not operate until you are sure all bystanders are clear of area.
- Coulter, disk and marker blades are sharp. Use extreme care when adjusting or servicing. Keep hands and feet from beneath blades.

SERVICE/MAINTENANCE

- Before working on this machine stop the tractor, set the brakes, disengage the PTO and power drive, shut off the engine and remove the ignition key.
- Securely block machine when working on or under it. To prevent injury in case of hydraulic failure or inadvertent lowering by another person, unfold wings and arms and securely block.
- Always use the proper tools or equipment for the job.
- Properly tighten all hardware.
- Relieve pressure from hydraulic system before servicing or disconnecting from tractor.
- Inspect all hydraulic hoses and components to be sure they are in good condition and that all connections are tight.
- Escaping hydraulic oil under pressure can produce enough force to penetrate the skin, causing serious personal injury or infection. Before applying pressure to the system, be sure all connections are tight and that lines, pipes, and hoses are not damaged. Before disconnecting lines, be sure to relieve all pressure. Hydraulic oil escaping from a very small hole can be almost invisible. Wear proper eye and hand protection and use a piece of cardboard or wood - not your hands - to search for suspected leaks. If injured by escaping hydraulic oil, **seek emergency medical attention immediately.** Serious infection or reaction can develop if proper medical treatment is not administered immediately.
- When remote cylinders are connected to the hydraulic system, cycle the control lever about three times to remove air from the cylinder and hoses. With air in the system, raised equipment can drop accidentally and cause personal injury or damage.
- Never use machine until all guards and safety devices are securely in place.

UNDERSTAND THAT YOUR SAFETY AND THE SAFETY OF OTHER PERSONS IS MEASURED BY HOW YOU SERVICE AND OPERATE THIS MACHINE.

LEARN ALL SAFETY RULES FOR THIS CHOPPER-BEDDER AND TEACH THEM TO ANYONE WHO MIGHT OPERATE THIS MACHINE.

SAFETY SIGNS

- Keep safety signs clean and legible at all times.
- Replace safety signs that are missing or have become illegible.
- Replaced parts that displayed a safety sign must also display the current sign.
- Safety signs are available from your dealer or W & A Manufacturing Company.

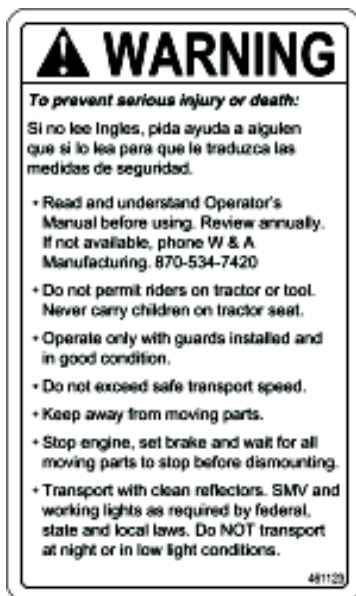

A. WARNING - Read Operator's Manual.
Sign Number 461123.

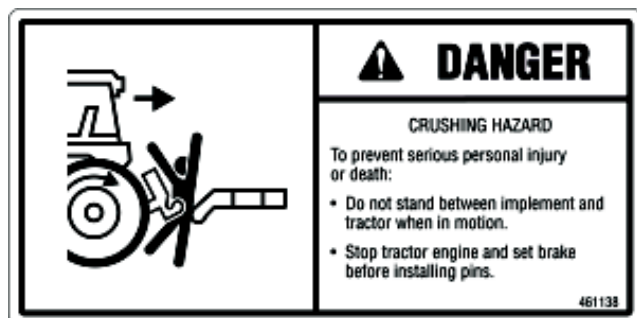

B. DANGER - Crushing Hazard.
Sign Number 461138

N/I. Yellow Reflector. Sign Number 461200. Two required. One at each end of front side of reel frame.

N/I. Red Reflector. Sign Number 461201. Two required. One at each end of rear tool bar.

LUBRICATION & MAINTENANCE



Lower Unit Before Servicing, Adjusting or Leaving Unit.

DAILY OR AFTER 10 HOURS OF OPERATION:

Grease all reel bearings.

Retighten all bolts and check that all fasteners and keepers are in place and secure.

PERIODICALLY:

Tighten bolts holding blades on reels.

Thoroughly clean and inspect your machine. Tighten all bolts as needed and check that all fasteners and keepers are in place and secure.

Be sure all hydraulic connections are tight and hoses are not worn or damaged. Hydraulic oil leaking under pressure can penetrate the skin and cause infection or other injury.

TO PREVENT PERSONAL INJURY:

Relieve all pressure before disconnecting lines. Before applying pressure, make sure all connections are tight and in good condition. Never use your hand to check for suspected leaks under pressure. Wear proper eye and hand protection and use a piece of cardboard or wood for this purpose. If injured by leaking fluid, SEE YOUR DOCTOR IMMEDIATELY.

Check hitch pins for wear and replace as required.

Grease all reel bearing assemblies and clean and repack wheel bearings before storing implement for an extended period of time.

Review safety instructions with all operators annually.



*Be Extra Cautious
around Moving Machinery!*

ADJUSTMENTS & OPERATION



Lower Unit Before Servicing, Adjusting or Leaving Unit.

- Adjust top link of tractor hitch so that both tool bars are level to assure equal height of beds. Both bars must be level.
- Set depth of chopper reels by adjusting ratchet crank of gauge wheels.
- Set height of beds by moving depth stop bolt on parallel brackets.
- Recommended working speed is five to seven miles per hour.
- Never attempt to turn around with machine in the down and working position.



INSTALL PROPER BALLAST ON FRONT OF TRACTOR TO INSURE SAFE AND PROPER STEERING AT ALL TIMES.



EXTREME CARE SHOULD BE USED WHEN HITCHING BAR TO TRACTOR TO PREVENT INJURY TO HANDS OR FINGERS. DO NOT STAND BETWEEN THE TOOL BAR AND TRACTOR WHEN IT IS IN MOTION. STOP TRACTOR ENGINE AND SET BRAKE BEFORE INSTALLING PINS.

ASSEMBLY



EXTREME CARE SHOULD BE USED DURING ASSEMBLY TO PREVENT INJURY TO HANDS, FINGERS AND FEET.



1. Mount reel frame assembly to three point hitch of appropriately sized tractor and park on a flat level surface.
2. Locate center of back side of main tube and make a mark. From center mark locate two inside parallel bracket as shown. Locate other brackets on equal spacing be sure that they are centered at LEAST 8 INCHES AWAY FROM A ROW MIDDLE.
3. Attach parallel brackets using U-bolts provided. Insure arm with welded stop bracket is on top and at front of machine.
4. Center rear disk bedder tool bar and attach to parallel brackets with U-bolts provided.

DISK BEDDERS MAY BE ASSEMBLED WITH EITHER OPPOSED GANGS OR STAGGERED GANGS. THE OPPOSED METHOD OF LONG BEAMS WORKING IN CONJUNCTION WITH LONG BEAMS AND SHORT BEAMS WORKING OPPOSITE SHORT BEAMS WILL NORMALLY PUT UP SLIGHTLY TALLER BEDS AND THE UNIT MAY PULL STRAIGHTER. MOST FARMERS USE THIS METHOD. THE STAGGERED ASSEMBLY METHOD OF A SHORT BEAM WORKING OPPOSITE A LONG BEAM MAY BE MORE DESIRABLE WHEN WORKING IN HIGH RESIDUE CONDITIONS.



**** OPPOSED SETTING ****

5. Locate and mark center of tool bar. Now mark bar from center mark at desired row spacing. Lay-out for six row will have 7 marks, eight row 9 marks, and twelve row 13 marks.
6. With the opposed setting the gangs are mounted to face each other in building the row. Starting at the center mark, attach one long beam and one short beam. Continue this on each mark using one long beam and one short beam until reaching the outside mark. At the outside mark, one beam is to be attached. This beam is located to the inside of the mark. Remember, this setting should have one long beam working against another long beam and short against short.

7. Next bolt the blade assemblies onto the beams. All these assemblies are the same. Bolt the blade assemblies into position allowing the long beams to throw soil at each other and the short beam throwing soil at each other. For proper installation of blade assembly onto beam see picture.
8. Clamp one gauge wheel to each end of the front of reel frame assembly with wheels turned to the inside to allow tires to work in middles.
9. Adjust top link of tractor so that both tool bars are level to assure equal height of beds.



INSTALL PROPER BALLAST ON FRONT OF TRACTOR TO INSURE SAFE AND PROPER STEERING AT ALL TIMES.



EXTREME CARE SHOULD BE USED WHEN HITCHING BAR TO TRACTOR TO PREVENT INJURY TO HANDS OR FINGERS. DO NOT STAND BETWEEN THE TOOL BAR AND TRACTOR WHEN IT IS IN MOTION. STOP TRACTOR ENGINE AND SET BRAKE BEFORE INSTALLING PINS.

SAFETY FIRST



**ACCIDENTS
DON'T JUST HAPPEN
THEY ARE CAUSED**

REEL FRAME

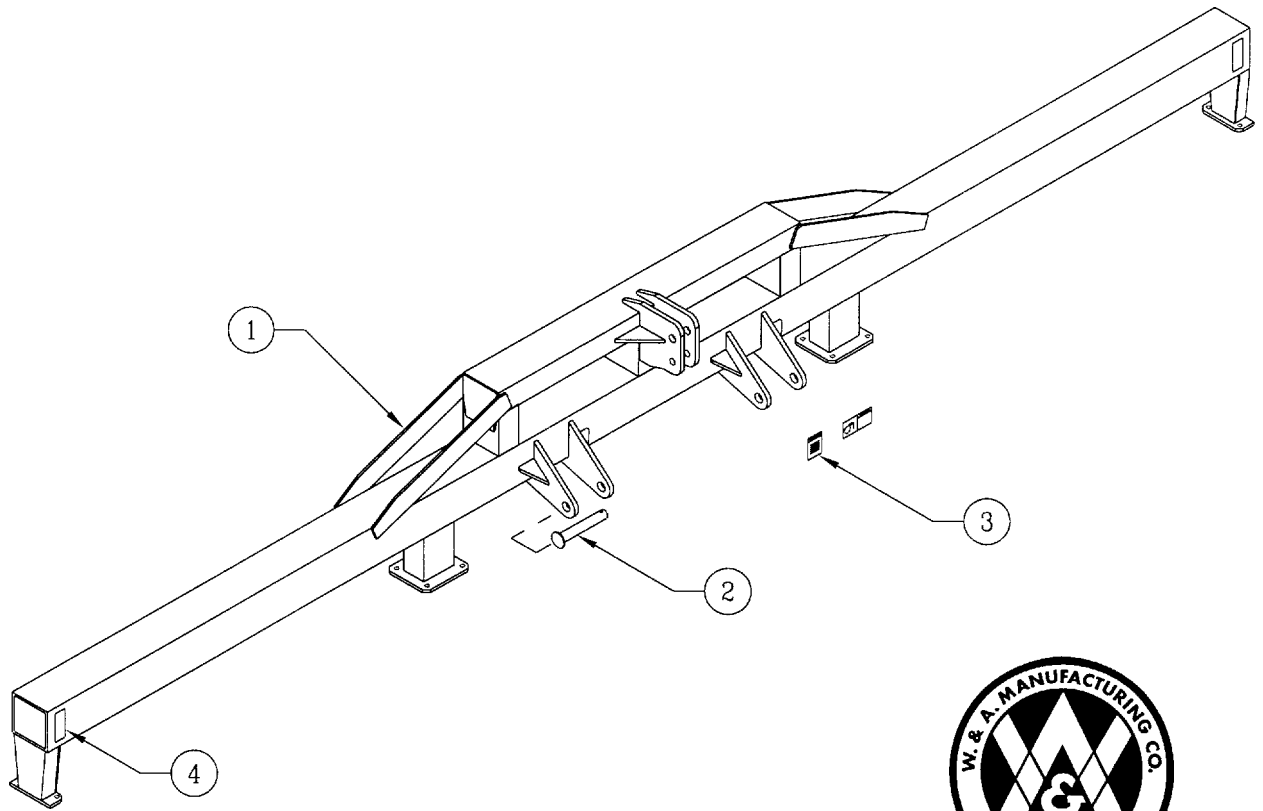

Item No.	Part No.	Wt. Lbs.	Description	Qty. Req'd
1	302248	994	Six Row 38"/40" Reel Frame	1
-	302249	1,369	Eight Row 38"/40" Reel Frame	1
-	302250	1,518	Twelve Row 30" Reel Frame	1
2	300841	4	Hitch Pin - 1-7/16" x 9"	2
-	416207	-	7/16" Klik Pin - Zinc	2
N/I	416698	2	1-1/4" Top Link Pin - Zinc (6-1/2")	1
-	416207	-	7/16" Klik Pin - Zinc	1
3	461123	-	"Warning - Read Operator's Manual" Safety Sign	1
-	461138	-	"Danger - Crushing Hazard" Safety Sign	1
4	461200	-	Yellow Reflector	2
-	461201	-	Red Reflector (One at each end of rear tool bar)	2

REEL

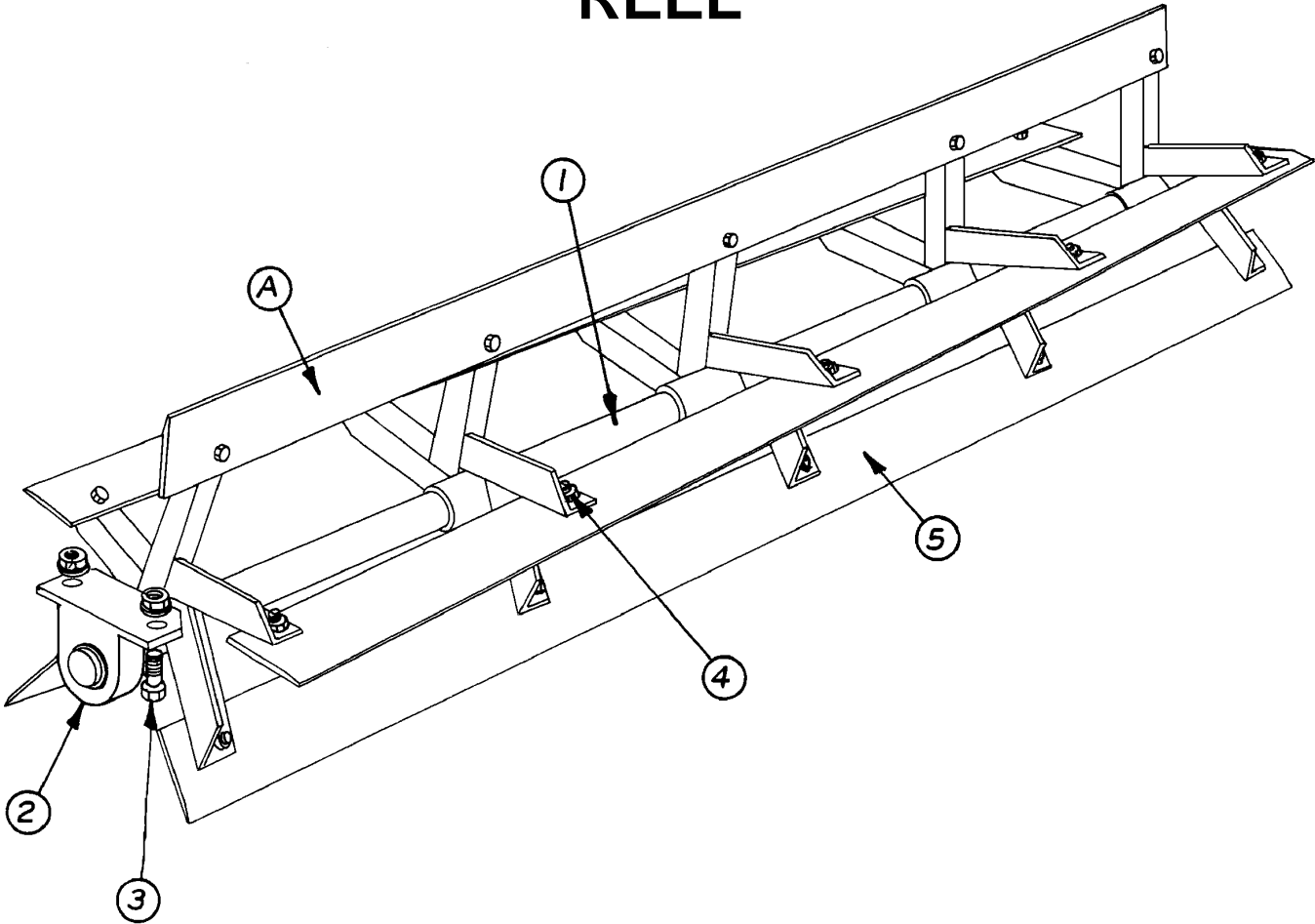

Item No.	Part No.	Wt. Lbs.	Description	Qty. Req'd for 1 Reel
A	770020	235	Spiral 6 ft Reel Complete w/Bearings	1
-	770030	288	Spiral 84" Reel Complete w/Bearings.....(For 12 @ 30")	1
1	300451	116	1-15/16" x 77" Shaft w/5 spiral brackets only	1
-	302149	152	1-15/16" x 89" Shaft w/6 spiral brackets only	1
2	482101	4	1-15/16" Pillow Block & Bearing - Pulv	2
-	481215	1	1-15/16" Bearing w/Lock Collar Peer - #G1115-KRRB-S1115K	2
-	480006	3	Pillow Block for 1-15/16" Bearing	2
-	480005	-	Lock Collar Only	2
3	411214	¼	Hex Bolt -- 5/8" x 2" NC - Gr 2 - Zinc	4
-	412010	-	Hex Nut -- 5/8" - 11 - Gr 2 - Zinc	4
-	413510	-	Lock Washer -- 5/8" - Zinc	4
4	411211	¼	Hex Bolt -- 5/8" x 1-1/4" NC - Gr 2 - Zinc	25
-	410009	-	Lock Nut -- 5/8" NC - Zinc	25
5	200539	20	Spiral Pulv Blade x 72"(9/32" x 4" x 72")	5
-	204482	24¾	Spiral Pulv Blade x 84"(9/32" x 4" x 84")	5

HEAVY DUTY CAST BEAM 1-1/8" SQ. AXLE DISK BEDDER

No. 710124

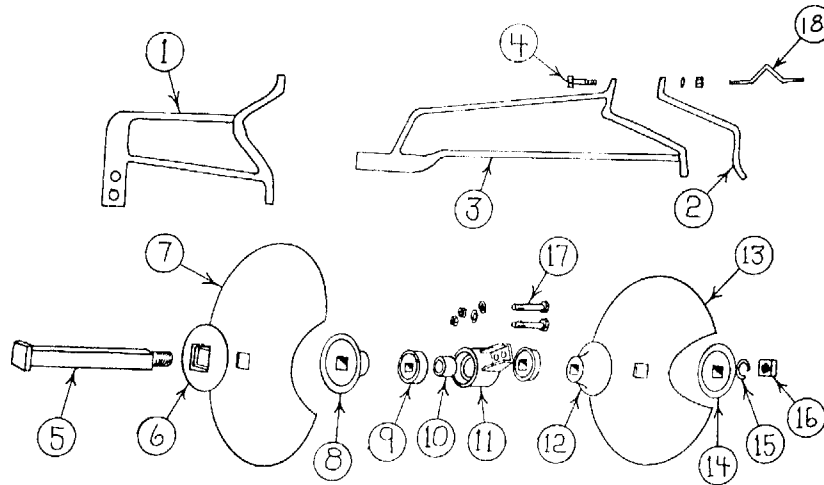

<u>Item No.</u>	<u>Part No.</u>	<u>Wt. Lbs.</u>	<u>Description</u>	<u>Qty. Req'd. for One Row</u>
1	478004	35	Front Beam -- 4 x 7 Tool Bar	1
2	407012	8	Backing Clamp 4 x 7 Bar -- 3/4"	2
3	478005	42	Rear Beam -- 4 x 7 Tool Bar	1
4	411565	-	Hex Bolt -- 5/8" x 3-1/2" NC - Gr 5 - Zinc	8
-	412010	-	Hex Nut -- 5/8" - 11 - Gr 2 - Zinc	8
-	413510	-	Lock Washer -- 5/8" - Zinc	8
5	478100	5	1-1/8" Sq. x 12-3/8" Axle (Bedder)	2
6	478020	5	6" Concave Disk Washer -- 1-1/8" Axle DB	2
7	473018	12	18" x 9 Ga Plain Blade -- 1-1/8" Sq Ctr Hole	2
-	473020	15	20" x 9 Ga Plain Blade -- 1-1/8" Sq Ctr Hole	
8	201492	4	Convex Bearing Spacer -- 1-1/8" Axle DB	2
9	481202	1	Sealed Bearing - Bedder - 1-1/8"	4
10	200881	1/2	Bearing Spacer -- 1-1/8" Axle Bedder	2
11	201306	10 1/4	Bearing Housing -- 1-1/8" Axle Bedder	2
-	710004	13 1/2	Bearing Housing with Bearings	
12	201493	4	Concave Bearing Spacer -- 1-1/8" Axle DB	2
13	473016	8	16" x 9 Gauge Disk Blade	2
14	201494	4	Concave Axle Washer -- 1-1/8" Axle Bedder	2
15	413518	-	Lock Washer -- 1-1/8" - Zinc	2
16	412318	-	Square Nut -- 1-1/8" - 7 - Gr 2 - Zinc	2
17	411220	-	Hex Bolt -- 5/8" x 3-1/2" NC - Gr 2 - Zinc	4
-	412010	-	Hex Nut -- 5/8" - 11 - Gr 2 - Zinc	4
-	413510	-	Lock Washer -- 5/8" - Zinc	4
N/I	710035	4 1/2	Scraper (Pair)	1

PARALLEL BRACKET

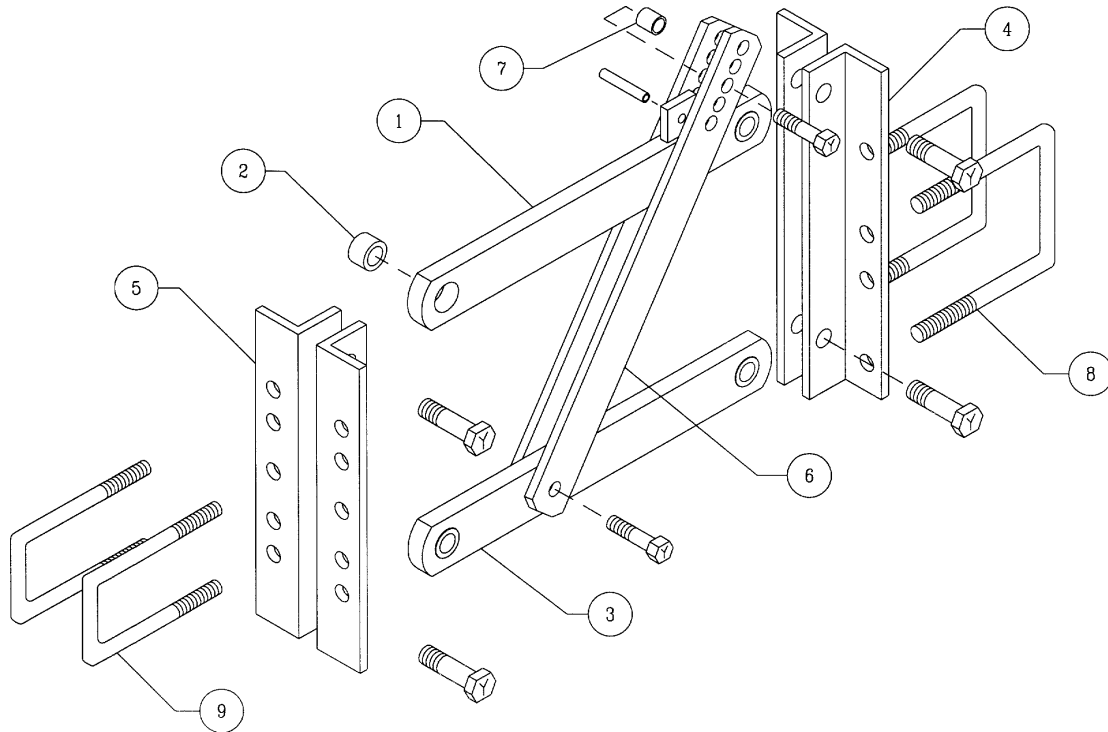

<u>Item No.</u>	<u>Part No.</u>	<u>Wt. Lbs.</u>	<u>Description</u>	<u>Qty. Req'd. for One Brkt.</u>
1	302253		Top Stop Arm	1
-	4161131	-	Roll Pin -- 1/2" x 2-1/2"	1
2	204578	1/2	Arm Bushing -- 1-5/8" OD x 1-1/16" Long	4
-	411642	1	Hex Bolt -- 1" x 3-1/2" NC - Gr. 5 - Zinc	4
-	412016	1/4	Hex Nut -- 1" - 8 - Gr. 2 - Zinc	4
-	413516	-	Lock Washer -- 1" - Zinc	4
3	204571		Bottom Arm	1
4	204573		Front Angle - RH	1
-	204574		Front Angle - LH	1
5	204575		Rear Angle	2
6	204576		Stop Arm	2
7	204577	-	Stop Arm Spacer	1
-	411589		Hex Bolt -- 3/4" x 3" NC - Gr. 5 - Zinc	2
-	412012		Hex Nut -- 3/4" - 10 - Gr. 2 - Zinc.	2
-	413512		Lock Washer -- 3/4" - Zinc	2
8	415021		7/8" Sq. U-Bolt x 7" x 9" Leg	2
-	412014	1/4	Hex Nut -- 7/8" - 9 - Gr. 2 - Zinc	4
-	413014	-	Lock Washer -- 7/8" - Zinc	4
9	415006	3	3/4" Sq. U-Bolt x 4" x 8-1/2" Leg	2
-	412012	-	Hex Nut -- 3/4" - 10 - Gr. 2 - Zinc	4
-	413512	-	Lock Washer -- 3/4" - Zinc	4

RATCHET ADJ. GAUGE WHEELS

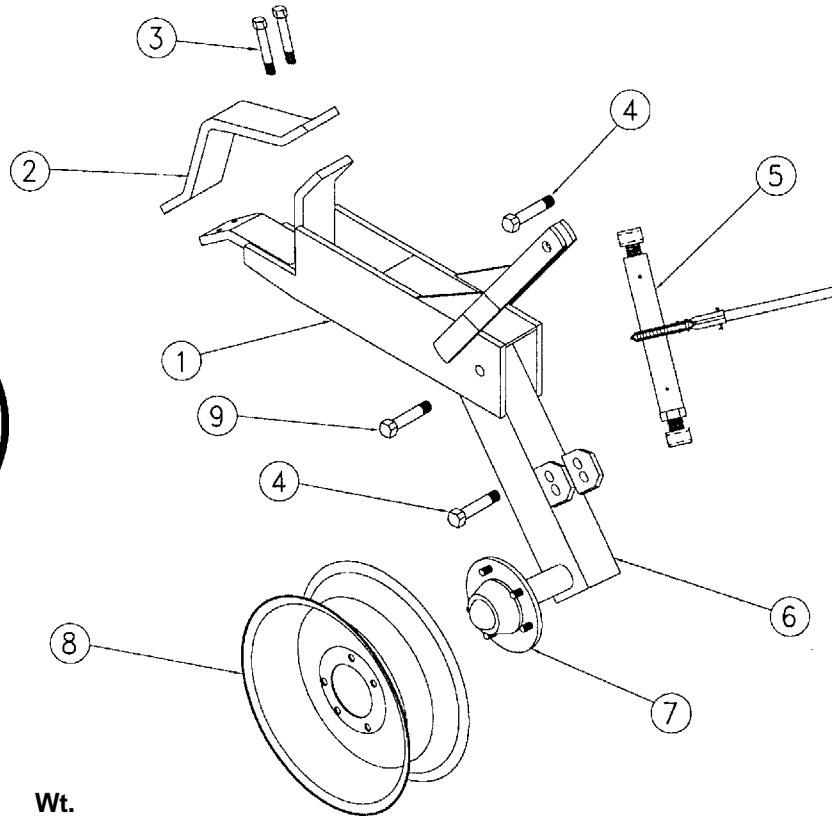

**No. 1338
& 1339**

<u>Item No.</u>	<u>Part No.</u>	<u>Wt. Lbs.</u>	<u>Description</u>	<u>Qty. Req. for 1 Assembly</u>
1	302225	60	Holder	1
2	203770	10	Backing Clamp for 7" x 7" Bar	1
3	411591	½	Hex Bolt -- 3/4" x 4" NC - Gr 5 - Zinc	4
-	412012	-	Hex Nut -- 3/4" - 10 - Gr 2 - Zinc	6
-	413512	-	Lock Washer -- 3/4" - Zinc.....	6
4	411591	½	Hex Bolt -- 3/4" x 4" NC - Gr 5 - Zinc	2
5	302025	11½	Ratchet Crank Assembly	1
6	302226	34¾	RH Leg w/Hub -- #1338 Gauge Wheel (Shown)	1
-	302227	34¾	LH Leg w/Hub -- #1338 Gauge Wheel	1
7	491119	11	5 Hole Hub Complete - Q-719	1
-	491007	9¾	Hub w/Cups Only - Q-719.....	1
-	481205	¼	Cone - Q719 - LM67048	1
-	496010	-	Outer Cup - Q719 - LM67010	1
-	481204	¼	Cone - Q719 - LM48548	1
-	496011	-	Inner Cup - Q719 - LM48510	1
-	497010	-	Grease Seal - Q719 - CR 15190	1
-	490006	¼	Hub Cap - Q719	1
-	490015	-	1/2" NF Lug Nut	5
-	490017	-	Drive-In Hub Bolt - Q719	5
-	412164	-	Slotted Nut -- 7/8" - 14 Spindle	1
-	490034	-	Spindle Washer -- 7/8" - Q719	1
8	493007	17	15" x 5" x 5 Hole Wheel.....	1
9	411594	¾	Hex Bolt -- 3/4" x 5" NC - Gr 5 - Zinc	1
-	412012	-	Hex Nut -- 3/4" - 10 - Gr 2 - Zinc	1
-	413512	-	Lock Washer -- 3/4" - Zinc.....	1

WARRANTY

W & A Manufacturing Company warrants all products manufactured and sold by it to be free of defects in material and workmanship and to perform as represented, subject to the following conditions

- (A) Warranty applies only if installed and operated according to instructions.
- (B) Written authorization must be obtained prior to return of material for inspection. Material is to be returned prepaid.
- (C) Warranty does not apply to labor for parts replacement, nor does it apply to damage by accident, abuse, misuse or failure caused by not operating according to instructions.
- (D) Warranty is void if changes are made in the product in the field by other than a W & A representative or by instructions from the factory.

W & A Manufacturing Company reserves the right at any time to make changes in the design, materials and/or specifications of any of its products without thereby becoming liable to make similar changes in equipment previously manufactured.

Written authorization must be obtained prior to the return of any equipment purchased from W & A Manufacturing Company. No penalties will be charged if equipment had been placed on display by a W & A representative or if reasons for return are errors or faults of W & A Manufacturing Company. If return is for the benefit of the customer and the equipment is returned by prepaid freight in a new, unused and resalable condition, credit (based on original purchase price) will be issued less a 10% fee for restocking and other handling expenses.



Quality Products from

W & A MANUFACTURING COMPANY

P.O. Box 5238, Pine Bluff, Arkansas 71611

Phone: (870) 534-7420

Fax: (800) 336-1318

Website: www.wamfgco.com