

W & A

PARTS MANUAL



12 ROW @ 36"

STACKER BUSTER PULVAMIZER

Model No. 3647



Quality Products from

W & A MANUFACTURING COMPANY

P.O. Box 5238, Pine Bluff, Arkansas 71611

Phone: (870) 534-7420

Fax: (800) 336-1318

Website: www.wamfgco.com

CENTER SECTION

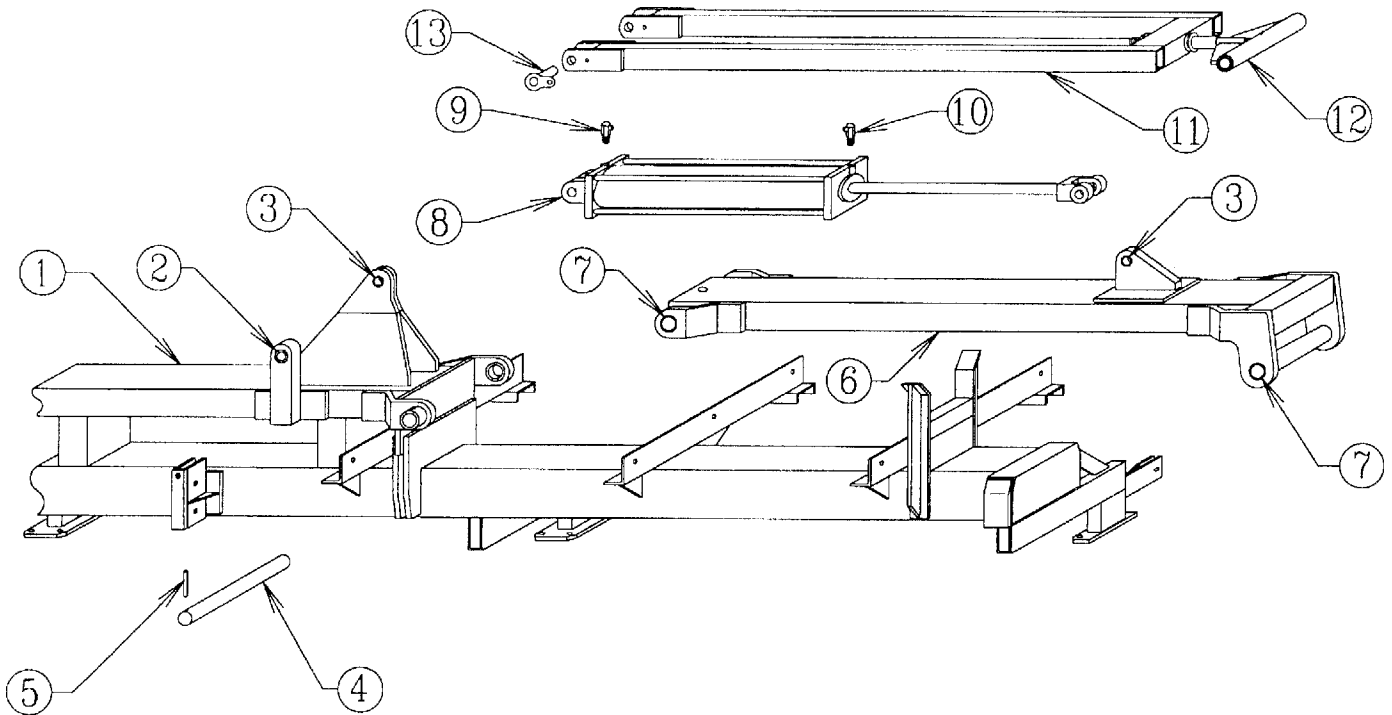

USE ONLY



W & A REPLACEMENT PARTS

CENTER SECTION

ITEM NO.	PART NO.	WT. LBS.	DESCRIPTION	QTY. REQUIRED
1	302172	1744	Center Section	1
2	401084	¼	Form 1 Bushing -- 1½" OD x 1¼" ID x 1½" Long	4
3	401080	¼	Form 1 Bushing -- 1-1/2" OD x 1-1/4" ID x 1" Long....	4
4	203948	14¼	2" Pivot Pin	4
-	413124	-	Machine Washer -- 3" OD x 2" ID x 10 Ga	8
5	416133	-	Roll Pin -- 1/2" x 3-1/2" - Zinc	4
6	301802	265	Power Arm -- Top Leveling Stacker	2
7	401118	½	Bushing -- 2.376" OD x 2.006" ID x 2" Long	8
-	450004	-	1/4" Drive-in Grease Fitting	4
8	476029	126	Hydraulic Cylinder -- 5" x 30".....(w/Pins)	2
-	477056	-	Seal Kit -- 5" x 24" & 5" x 30" Lion Cyl (2" rod)	-
9	446188	¼	1/2" x 1/2" Swivel Orifice Elbow	2
10	444024	¼	Swivel, ½" x ½"	2
-	785103	½	3/8" Hydraulic Hose x 103"	2
-	785120	½	3/8" Hydraulic Hose x 120"	2
11	301820	88	Leveling Arm (For 1½" Dia. Rod)	2
12	301819	19¾	Leveling Arm End – 1½" Dia.Rod	2
-	410032	1	Lock Nut -- 1-1/2" NF Nylon Insert - Zinc	2
-	412024	¾	Hex Nut -- 1-1/2" - 6 - Gr 2 - Zinc	2
-	413120	-	Machine Washer -- 1-1/2" ID x 10 Ga	2
-	450004	-	1/4" Drive-in Grease Fitting	2
-	401095	-	Form 1 Bushing -- 1-7/8" OD x 1-1/2" ID x 1"Long....	4
13	301824	1¾	Small Pin -- 1-1/4" x 2-1/2" Stacker Bar	4
-	411545	-	Hex Bolt -- 1/2" x 1-1/2" NC - Gr 5 - Zinc	4
-	413008	-	Flat Washer -- 1/2" - Zinc	4

WING

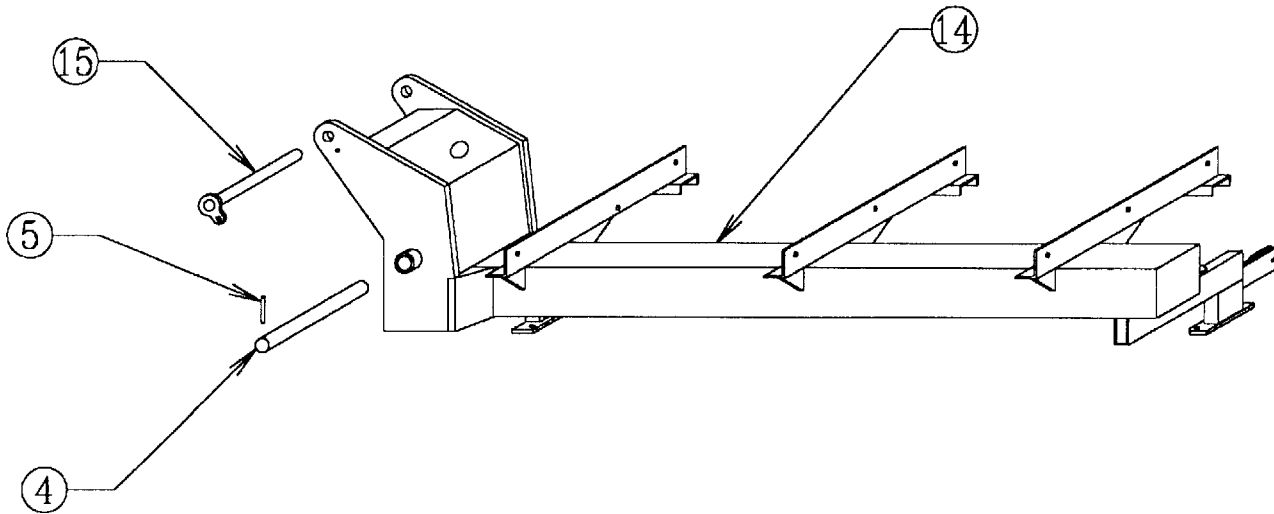

<u>ITEM NO.</u>	<u>PART NO.</u>	<u>WT. LBS.</u>	<u>DESCRIPTION</u>	<u>QTY. REQUIRED</u>
4	203948	14¼	2" Pivot Pin	4
-	413124	-	Machine Washer -- 3" OD x 2" ID x 10 Ga.....	8
5	416133	-	Roll Pin -- 1/2" x 3-1/2" - Zinc	4
14	302174	604	Wing – LH (Shown)*	1
-	302173	604	Wing – RH*	1
15	301825	8	Top Pin -- Top Leveling Stacker	2
-	411545	-	Hex Bolt -- 1/2" x 1-1/2" NC - Gr 5 - Zinc	2
-	413008	-	Flat Washer -- 1/2" - Zinc	2



BOLT-ON SHANK HOLDERS

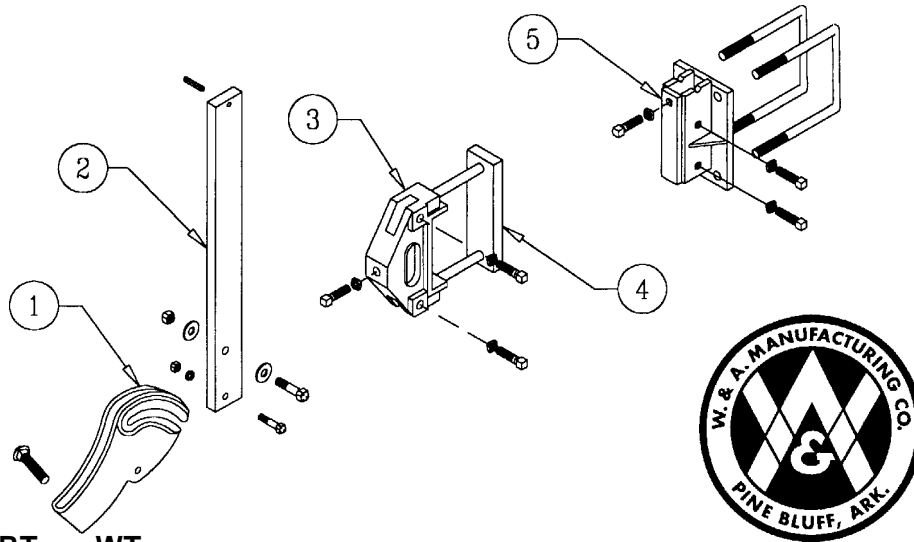

<u>ITEM NO.</u>	<u>PART NO.</u>	<u>WT. LBS.</u>	<u>DESCRIPTION</u>	<u>QTY. REQ.</u>
1	479075	6½	Friction Trip Foot (Bed Maker)	13
-	411549	-	Hex Bolt -- 1/2" x 2-1/2" NC - Gr 5 - Zinc	13
-	411563	½	Hex Bolt -- 5/8" x 3" NC - Gr 5 - Zinc	13
-	411794	½	Carriage Bolt -- 3/4" x 3-1/2" NC - Gr 5 - Zinc	13
-	410009	-	Lock Nut -- 5/8" NC - Zinc	13
-	410012	-	Lock Nut -- 3/4" NC - Zinc	13
-	412008	-	Hex Nut -- 1/2" - 13 - Gr 2 - Zinc	13
-	413010	-	Flat Washer -- 5/8" - Zinc	26
-	413012	-	Flat Washer -- 3/4" - Zinc	26
-	413508	-	Lock Washer -- 1/2" - Zinc	13
2	204210	25	Vertical Shank C1080 (Bed Maker)	9
-	416120	-	3/8" x 2" Roll Pin - Zinc	13
3	479069	13½	Bolt-On Shank Holder	10
-	414828	-	Square Head Set Screw -- 5/8" x 1-3/4"	30
-	412310	-	Square Nut -- 5/8" - 11 - Gr 2 - Zinc	30
-	412410	-	Jam Nut -- 5/8" - 11 - Gr 2 - Zinc	30
4	204274	9	Backing Plate	10
-	411601	1¼	Hex Bolt -- 3/4" x 8-1/2" - Gr. 5 - Zinc	20
-	412012	-	Hex Nut -- 3/4" - 10 - Gr 2 - Zinc	20
-	413512	-	Lock Washer -- 3/4" - Zinc	20
5	302036	19½	Center Bolt-On Shank Holder	2
-	415004	2½	3/4" Sq. U-Bolt x 7" x 9" Leg	4
-	412012	-	Hex Nut -- 3/4" - 10 - Gr 2 - Zinc	8
-	413512	-	Lock Washer -- 3/4" - Zinc	8
-	414828	-	Square Head Set Screw -- 5/8" x 1-3/4"	6
-	412410	-	Jam Nut -- 5/8" - 11 - Gr 2 - Zinc	6
N/I	302002	28	3" Offset Shank – RH	1
N/I	302003	28	3" Offset Shank – LH	1
N/I	302034	27¾	1" Offset Shank – RH	1
N/I	302035	27¾	1" Offset Shank – LH	1

NOTE: On 12@ 36" Row Buster Pulvamer -- ONE Shank Holder is welded on frame.

REEL

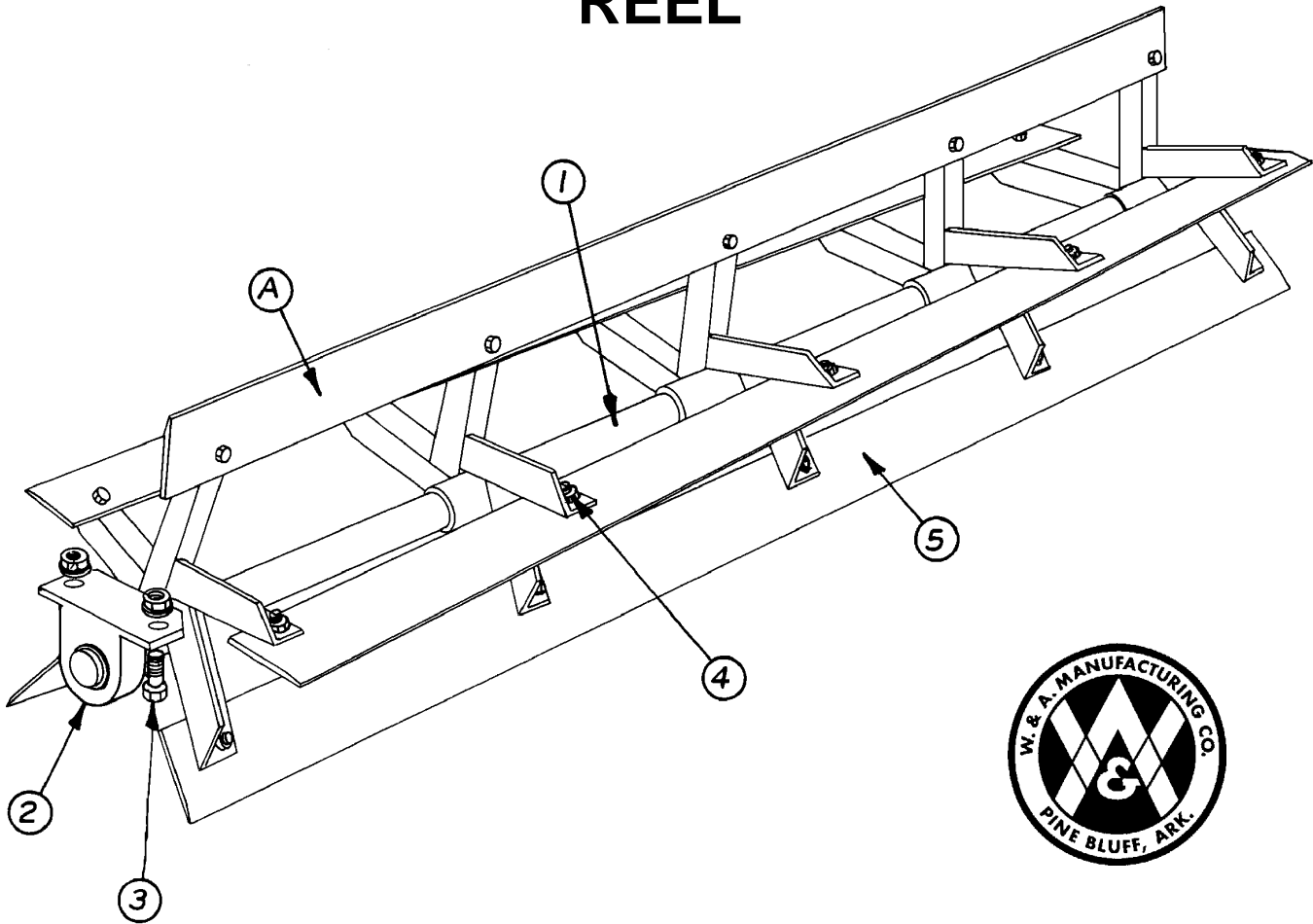

<u>ITEM NO.</u>	<u>PART NO.</u>	<u>WT. LBS.</u>	<u>DESCRIPTION</u>	<u>QTY. REQ'D FOR 1 MACHINE</u>
A	770020	235	Spiral 6 ft Reel Complete w/Bearings	3
-	770032	301	Complete Spiral 89" Reel w/Bearings for Wings	2
1	300451	116	77" Reel Shaft w/5 Support Brackets	3
-	301127	167	94-1/2" Reel Shaft w/6 Support Brackets	2
2	482101	4	1-15/16" Pillow Block & Bearing - Pulv.	10
-	481215	1	1-15/16" Bearing w/Lock Collar Peer - #G1115-KRRB-S1115K ...	-
-	480006	3	Pillow Block for 1-15/16" Bearing	-
3	411562	-	Hex Bolt -- 5/8" x 2-1/2" NC - Gr 5 - Zinc	20
-	410009	-	Lock Nut -- 5/8" NC - Zinc	20
-	413010	-	Flat Washer -- 5/8" - Zinc	20
4	411211	-	Hex Bolt -- 5/8" x 1-1/4" NC - Gr 2 - Zinc	145
-	410009	-	Lock Nut -- 5/8" NC - Zinc	145
5	200539	20	Spiral Pulvamerizer Blade x 72"	15
-	202335	25	Pulvamerizer Blade x 89"	10

FRAME & DRAGBOARDS

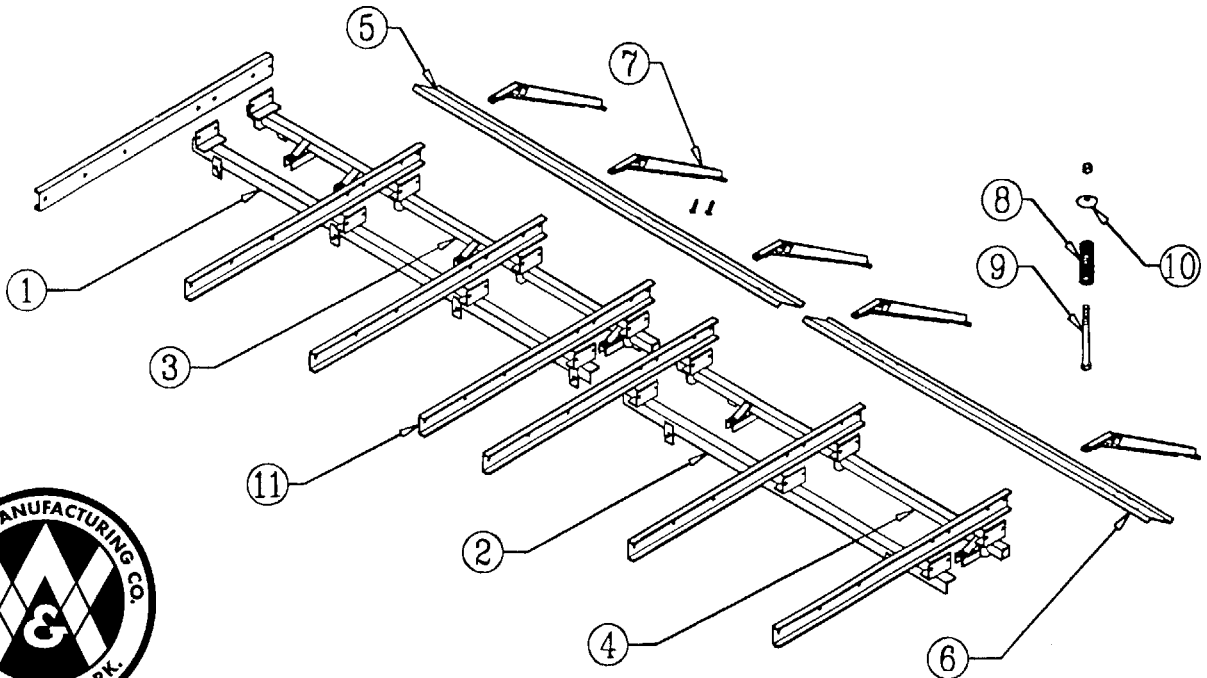

ITEM NO.	PART NO.	WT. LBS.	DESCRIPTION	QTY. REQUIRED
1	302175	128	Front Center Harrow Frame	1
2	302176	51	Front Left Hand Frame (Shown)	1
-	302177	51	Front Right Hand Frame	1
3	302178	208	Rear Center Harrow Frame	1
4	302179	85	Rear Left Hand Frame (Shown)	1
-	302180	85	Rear Right Hand Frame	1
5	202322	54	10'0" Metal Dragboard LH -- 6N 12 NF.....(Shown)	1
-	202509	54	10'0" Metal Dragboard RH -- 6N 12NF	1
6	202333	41	94-1/2" Steel Wing Dragboard	2
7	300388	17	Dragboard Bracket (Pulv)	10
-	411188	1/4	Hex Bolt -- 1/2" x 3" NC - Gr 2 - Zinc	10
-	410008	-	Lock Nut -- 1/2" NC - Zinc	10
-	411729	-	Carriage Bolt -- 1/2" x 1-1/4" NC - Gr 2 - Zinc	20
-	412008	-	Hex Nut -- 1/2" - 13 - Gr 2 - Zinc*	20
-	413508	-	Lock Washer -- 1/2" - Zinc*	20
(* Attaches bracket to dragboard)				
8	471006	1 1/2	Compression Spring Dragboard Leg	10
9	411237	1	Hex Bolt -- 5/8" x 8" NC - Gr 2 - Zinc	10
-	410009	-	Lock Nut -- 5/8" NC - Zinc	10
10	202350	-	Cup Washer for Pulv Dragboard Brkt Spg	10
11	404024	41	Connecting Channel- 75-3/8"	12
-	411212	-	Hex Bolt -- 5/8" x 1-1/2" NC - Gr 2 - Zinc	84

HARROWS

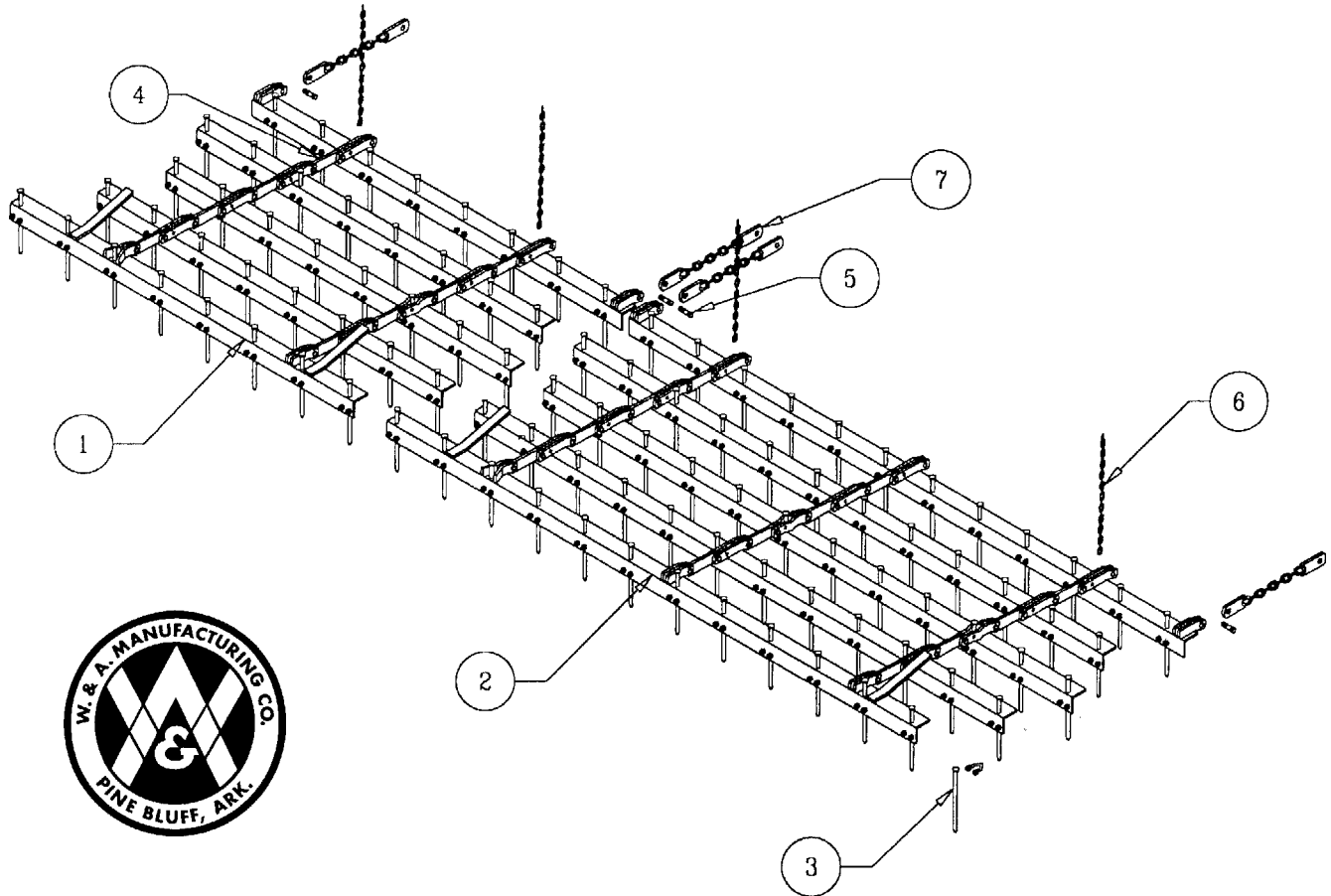

ITEM NO.	PART NO.	WT. LBS.	DESCRIPTION	QTY. REQ'D
1	773023	291	6' Heavy N3P Harrow w/Bushings (9 Link Pull Chains)* ...	3
2	773030	360	92" Heavy N3P Harrow w/Bushings (9 Link Pull Chains)*.	2
3	472010	1¾	¾" x 11" Harrow Tooth	40/50
-	415105	-	¾" V-Bolt x 1-1/8" x 2" Leg (Adj. Harrow)	40/50
4	773013	1¼	Harrow Conn. Link w/Bushings - (4-1/2" Long)	8/12
-	401055	-	Spring Bushing for Harrow Pull Piece.....(5/8" ID)	-
-	200557	1	Short Connecting Link Only*	-
5	416633	¼	Clevis Pin Knurled & Threaded -- 5/8" x 2" - Zinc.....	18/26
-	410009	-	Lock Nut -- 5/8" NC - Zinc	18/26
6	402015	1	1/4" x 19 Link Chain.....(High Test)	4
-	416204	-	1/4" Klik Pin - Zinc	4
7	300582	3½	Pull Piece w/Bushings - N3P Harrow.....(9 Link)	2
-	401055	-	Spring Bushing for Harrow Pull Piece.....(5/8" ID)	-

HITCH ASSEMBLY

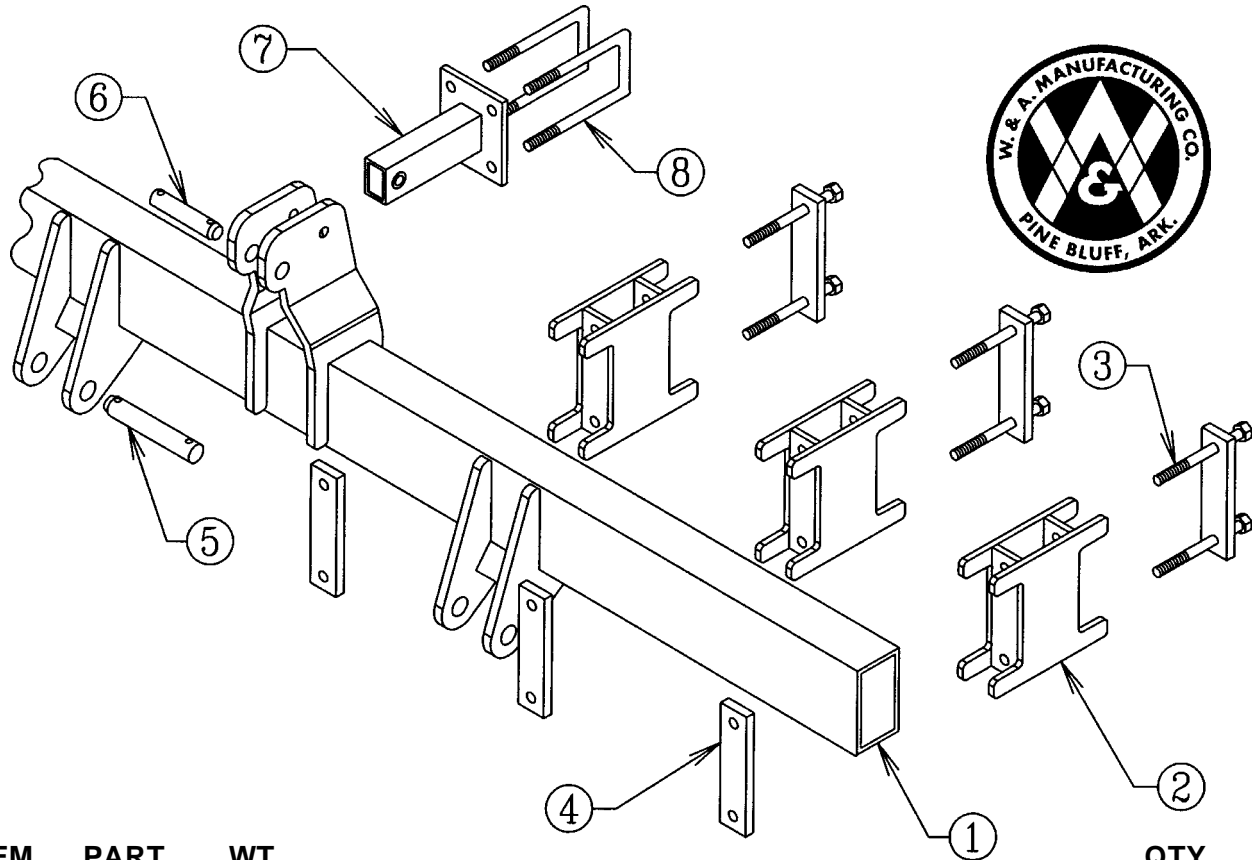

<u>ITEM NO.</u>	<u>PART NO.</u>	<u>WT. LBS.</u>	<u>DESCRIPTION</u>	<u>QTY. REQUIRED</u>
1	301833	361	Wide Hitch -- Top Leveling Stacker	1
2	302014	25	5" Spacer Block -- Top Leveling Stacker	6
3	411604	1¼	Hex Bolt -- 3/4" x 10" NC - Gr. 5 - Zinc	12
-	412012	-	Hex Nut -- 3/4" - 10 - Gr 2 - Zinc	29
-	413512	-	Lock Washer -- 3/4" - Zinc.....	29
4	203960	5	Backing Plate -- Top Leveling Stacker	6
-	411598	½	Hex Bolt -- 3/4" x 6-1/2" NC - Gr 5 - Zinc	12
5	200876	3¾	Hardened Pull Pin -- 1-7/16" x 8-3/8" - Zinc	2
-	416207	-	Klik Pin -- 7/16" - Zinc	2
-	416133	-	Roll Pin -- 1/2" x 3-1/2" - Zinc	2
6	200853	2	Hardened Top Link Pin -- 1-1/4" - Zinc	1
-	416207	-	Klik Pin -- 7/16" - Zinc	1
-	416120	-	Roll Pin -- 3/8" x 2" - Zinc	1
7	301836	11	Top Connector, 5" Spacer - Hitch Assy (SBM)	1
-	411594	¾	Hex Bolt -- 3/4" x 5" NC - Gr 5 - Zinc	1
8	415006	2	3/4" Sq. U-Bolt x 4" x 8-1/2" Leg.....	2

RATCHET ADJ. GAUGE WHEELS

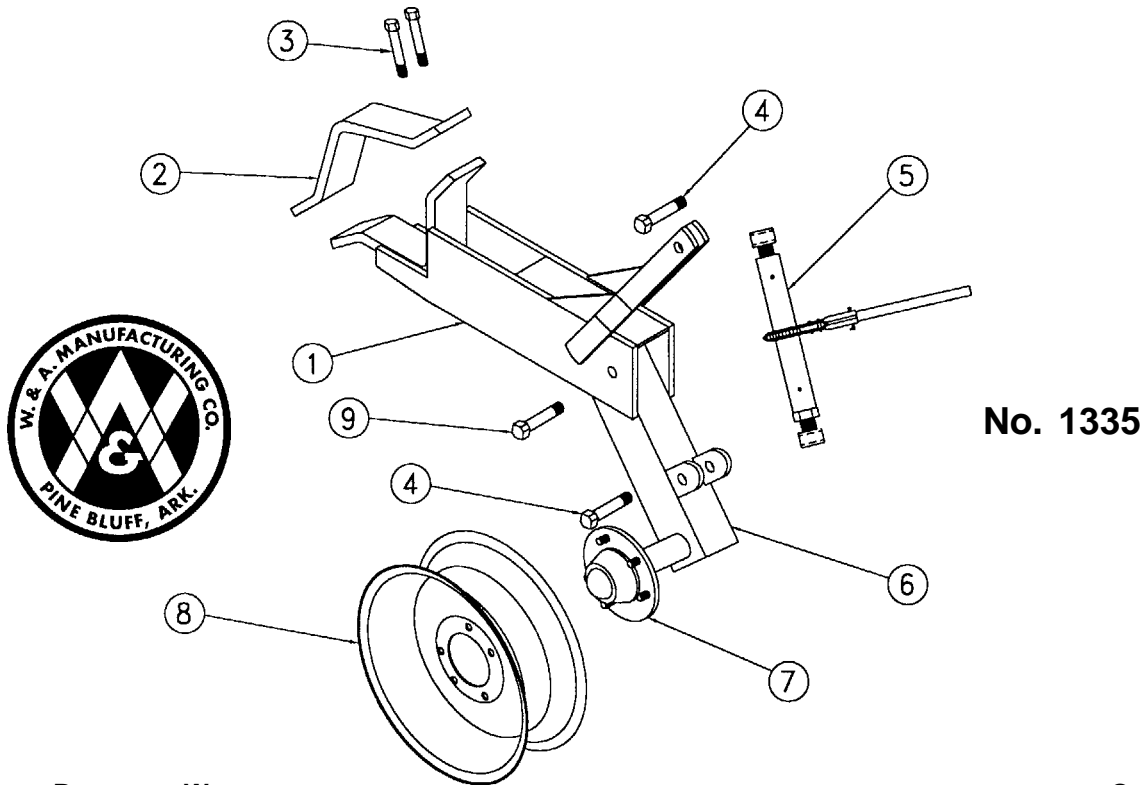

No. 1335

Item No.	Part No.	Wt. Lbs.	Description	Qty. Req'd
1	301611	60	Holder	1
2	202320	10	Backing Clamp for 7" x 7" Bar	1
3	411565	¼	Hex Bolt -- 5/8" x 3-1/2" NC - Gr 5 - Zinc	4
-	412010	-	Hex Nut -- 5/8" - 11 - Gr 2 - Zinc	4
-	413510	-	Lock Washer -- 5/8" - Zinc	4
4	411251	½	Hex Bolt -- 3/4" x 4" NC - Gr 2 - Zinc	2
-	412012	-	Hex Nut -- 3/4" - 10 - Gr 2 - Zinc	2
-	413512	-	Lock Washer -- 3/4" - Zinc	2
5	302025	11½	Ratchet Crank Assembly	1
6	301605	34	RH Leg w/Hub -- #1335 Gauge Wheel	1
-	301606	34	LH Leg w/Hub -- #1335 Gauge Wheel	1
7	491119	11	5 Hole Hub Complete - Q-719	1
-	491007	9¾	Hub w/Cups Only - Q-719	1
-	481205	¼	Cone - Q719 - LM67048	1
-	496010	-	Outer Cup - Q719 - LM67010	1
-	481204	¼	Cone - Q719 - LM48548	1
-	496011	-	Inner Cup - Q719 - LM48510	1
-	497010	-	Grease Seal - Q719 - CR 15190	1
-	490006	¼	Hub Cap - Q719	1
-	490015	-	1/2" NF Lug Nut	5
-	490017	-	Drive-In Hub Bolt - Q719	5
-	412164	-	Slotted Nut -- 7/8" - 14 Spindle	1
-	490034	-	Spindle Washer -- 7/8" - Q719	1
8	493007	17	15" x 5" x 5 Hole Wheel	1
9	411254	¾	Hex Bolt -- 3/4" x 5" NC - Gr 2 - Zinc	1
-	412012	-	Hex Nut -- 3/4" - 10 - Gr 2 - Zinc	1
-	413512	-	Lock Washer -- 3/4" - Zinc	1

USE ONLY

W & A REPLACEMENT PARTS



W & A Manufacturing Company

**1810 Ohio Street
Phone (870) 534-7420**

**P.O. Box 5238
Fax (800) 336-1318**

PINE BLUFF, ARKANSAS 71611

www.wamfgco.com